

**50th Annual Regional Anesthesiology and
Acute Pain Medicine Meeting**

May 1 – 3, 2025
Rosen Shingle Creek
Orlando, FL

Dear Exhibitor:

As the Official General Service Contractor, we would like to welcome you to the **50th Annual Regional Anesthesiology and Acute Pain Medicine Meeting**.

We have, along with Show Management, compiled this Exhibitor Services Manual to provide you with all of the necessary forms and vital information that you will need for a successful exposition experience.

In order to qualify for discount prices where available, please take time to review this manual now. To receive the discount prices your order(s) along with full payment must be received by the date indicated on the particular form. Please do not miss out on this opportunity to secure discounted prices. The savings offered to you are substantial.

Should you have any questions regarding any of the services or need assistance in planning your exhibit, please do not hesitate to contact our customer service department at 253 437 0031 or via email at operations@levyexpo.com. We will be happy to assist you in any way possible to ensure that you have a successful experience at the **50th Annual Regional Anesthesiology and Acute Pain Medicine Meeting**.

Thank you and we look forward to servicing your needs at the **50th Annual Regional Anesthesiology and Acute Pain Medicine Meeting** in **Orlando, FL**.

Sincerely,

Levy Exposition Services, Inc.



50th Annual Regional Anesthesiology and Acute Pain Medicine Meeting

QUICK FACTS

SERVICE CONTRACTOR CONTACT: LEVY EXPOSITION SERVICES INC.
14900 Interurban Avenue S., Suite 271
Seattle, WA 98168
T: 253 437 0031 F: 253 437 0032 E: operations@levyexpo.com

LOCATION: Rosen Shingle Creek
9939 Universal Blvd
Orlando, FL 32819

EXHIBITOR MOVE-IN: Wednesday, April 30, 2025 8:00 am – 5:00 pm ***Islands Only***
12:00 pm – 5:00 pm ***All Exhibits***
Thursday, May 1, 2025 8:00 am – 12:00 pm

EXHIBITION DATES: Thursday, May 1, 2025 12:00 pm – 1:30 pm ***Refreshments***
5:15 pm – 7:15 pm ***Opening Reception***
Friday, May 2, 2025 9:30 am – 4:30 pm ***Refreshments***
Saturday, May 3, 2025 9:30 am – 10:30 am ***Coffee***

EXHIBITOR MOVE-OUT: Saturday, May 3, 2024 10:30 am – 4:00 pm

****Please note that all exhibit materials must be removed from the exhibit Facility by 4:00 pm on Saturday, May 3, 2025.**

BOOTH EQUIPMENT: Each 10' x 10' booth space includes the following:

- 8' high drapery backwall – blue/white/yellow/white/blue
- 3' high drapery sidewall – blue
- 1 – 6' x 2' skirted table – blue
- 2 – side chairs
- 1 - wastebasket
- 1 - 7" x 44" booth identification sign

If you require additional furnishings or services please complete and return the appropriate enclosed order form(s).

EXHIBIT FLOOR: The exhibit floor will be carpeted in ballroom grade carpet.

CEILING HEIGHT: The ceiling height in the exhibit hall is 25 feet.

DISCOUNT PRICE DEADLINE: In order to receive the discount rates listed on the enclosed order forms, your **PAID** order is to be received by **April 10, 2025**.

LEVY ONLINE ORDERING (LOLO): The online ordering link and instructions will be sent via email to all exhibitors. Please provide your correct contact information to the show organizer to ensure you receive all necessary show information.

ELECTRICAL, A/V & RIGGING SERVICES: Electrical, A/V and Rigging Services are provided exclusively through Encore. To order services, please see **page 64** of this Exhibitor Kit.

INTERNET & TELECOM SERVICES: Internet Services are provided exclusively through Millennium Technology Group. To order services please see **pages 65 – 68** of this Exhibitor Kit.



50th Annual Regional Anesthesiology and Acute Pain Medicine Meeting

QUICK FACTS

LEAD RETRIEVAL SERVICES:

Lead Retrieval Services are provided exclusively through ExpoBadge. To order services please see **pages 69 – 71** of this Exhibitor Kit.

SHIPPING:

Please refer to the Material Handling order form in this manual for further information and associated costs.

All **ADVANCE WAREHOUSE** shipments should arrive between March 26, 2025 – April 23, 2025. Shipments arriving before or after these dates will incur an early/late surcharge. ***Please note that the warehouse will be closed on Friday, April 18, 2025 for the Good Friday Holiday.***

Shipments sent to the advance warehouse should be consigned as follows: (Labels are provided in the Material Handling Section of the manual)

50th ASRA RA
Exhibiting Company Name
Booth # ____
Levy Exposition Services, Inc.
c/o Liberty CFS NV, Inc.
3732 Brynn Mawr St
Orlando, FL 32808

All **DIRECT** shipments should not arrive prior to 8:00 am on **Wednesday, April 30, 2025**. Shipments arriving prior to this time will be refused.

Direct shipments should be consigned as follows: (Labels are provided in the Material Handling section of manual)

50th ASRA RA
Exhibiting Company Name
Booth # ____
Rosen Shingle Creek
c/o Levy Exposition Services, Inc.
9939 Universal Blvd
Orlando, FL

DISMANTLE AND MOVE-OUT INFORMATION:

All exhibitor materials **MUST** be removed from the facility by 4:00 pm on Saturday, May 3, 2025. To ensure that all exhibitor materials are removed by this time, please have your carrier check in no later than 2:00 pm on May 3rd. If your carrier does not check-in by this time, your shipment will be rerouted via the official carrier, Liberty CFS NV, Inc.

POST SHIPPING PAPERWORK:

Our customer service center will have outbound bills of lading and shipping labels for your convenience. Please note that Levy Exposition Services Bills Of Lading's (BOLs) **MUST** be filled out and turned into the service center once your materials are packed for all outbound shipments.

It is vital that your carrier knows your company name and booth # when you make your outbound shipping arrangements. Additionally, if your carrier plans to use a freight forwarding company to pick up your shipment(s), you **MUST** include this company's name as well as the actual shipping company's name on the bill of lading that you fill out. In the event someone other than the company listed on your outbound bill of lading arrives to pick up your shipment, it will be rerouted via the official show carrier.

ONLINE ORDERING INSTRUCTIONS

We are pleased to offer online ordering for the **50th Annual Regional Anesthesiology and Acute Pain Medicine Meeting**. This system is designed to assist in fulfilling your exposition needs simply, conveniently and securely.

Our online ordering links are unique to each exhibitor and are generated when exhibitors are imported to our online system. This creates a streamlined experience for exhibitors and eliminates the need to create a username and password.

1. You will receive an email from Levy Exposition Services with a copy of the PDF Exhibitor Kit and your account specific online ordering link. →
NOTE: If you do not receive your email, please email agaudet@levyshow.com and you will be sent one directly.

Levy Online Ordering Link:

[Click here to begin online ordering](#)

2. Once you have accessed the online ordering portal, you will be directed to the Welcome Page where you can access the Exhibitor Kit, Show Facts and other ancillary service forms. To begin online ordering, you can click the red "Order Booth Services" button. →
5. After making your service or rental selections, click the "Add to Cart" button. Once you have finished adding all items or services to your cart, click on the "My Cart/Orders" tab on the menu at the top of the page to view your order.
6. To complete your purchase click on the "Proceed to Checkout" button.
7. Complete your billing details and enter your credit card information to confirm and complete the order.
NOTE: Alternatively, to expedite the check out process, you may enter your card details before online shopping by clicking the "My Profile/CC" tab on the menu at the top of the page, then click "Credit Cards" and fill out the required information.

Exhibitor Information

ETK TEST
Booths: LEVY

Order Booth Services

Exhibitor Kit

Show Facts

Please click the blue links above for important show information and services.

OTHER HELPFUL INFORMATION:

1. To find your username and password, please click on the "My Profile/CC" tab on the menu at the top of the page.
2. To access and view your invoice(s), please click on the "My Invoice" tab on the menu at the top of the page.

SAFETY RULES

Exhibitors must provide adequate space within the exhibit to allow for the comfort and safety of persons watching demonstrations and/or placing orders. Each exhibitor is responsible for keeping the aisles near their booth free of congestion which may be caused by such demonstrations and/or order placement.

Aisles **MUST** remain free and clear of all obstructions. If chairs are being used as part of your exhibit, they **MUST** remain inside your booth space. Chairs in the aisle constitute a violation of fire codes and are also considered a booth violation.

Do not run electrical cords or position displays and/or product in such a way as to pose a safety hazard for attendees and company personnel who will traffic into booth areas.

Do not store cardboard cartons or packing materials in booth areas, as this is a violation of fire codes and poses a safety hazard.

Do not place product samples, whether on tables or free-standing displays, at the edge of the aisle, or in the case of an island booth, on shelving units on an outside wall. All portions of an Exhibitor's display must be contained within his/her assigned booth space, including chairs placed at the edge of an aisle.

At the close of the exhibit hall, please keep clear of all aisles including exhibit material and/or product. During the first two or three hours after the close of the exhibit hall, there is ample traffic in the aisles including but not limited to forklift traffic returning empty containers.

Union Jurisdictions for Orlando, Florida

To assist you in planning for your participation in this upcoming exposition, we are certain you will appreciate knowing in advance that union labor may be required for certain aspects of your exhibit handling. To help you understand the jurisdiction the various unions have, we ask that you read the following:

EXHIBIT INSTALLATION AND DISMANTLING

Currently we have an agreement with the Local IATSE Union to provide labor for display erection and dismantling. Full time employees of the exhibiting companies, however, may set their own exhibits without assistance from this local. Any labor services that may be required beyond what your regular full time employees can provide, may be rendered by the Union. Labor can be ordered in advance by returning the Display Labor form, or at showsite, at the service desk.

MATERIAL HANDLING

Exhibitors may hand-carry their own materials into the exhibit facility. The use or rental of dollies, flat trucks and other mechanical equipment, however, is not permitted. LEVY will control access to the loading docks in order to provide for a safe and orderly move-in/out. Only full time employees of the exhibiting company will be allowed to hand-carry items. Unloading or reloading at the dock of any and all contracted carriers will be handled by LEVY.

TIPPING

LEVY requests that exhibitors do not tip our employees. They are paid at an excellent wage scale denoting a professional status, and we feel that tipping is not necessary. This applies to all employees. Any request for such should be brought to the attention of a Levy representative at the service desk or correspondence may be directed to the attention of the General Manager at the Seattle office address.

SAFETY

Standing on chairs, tables, or other rental furniture is prohibited. This furniture is not engineered to support your standing weight. LEVY cannot be responsible for injuries or falls caused by the improper use of this furniture. If assistance is required in assembling your booth, please order labor on the Display Labor order form and the necessary ladders and tools will be provided.

EXHIBIT CONSTRUCTION GUIDELINES SUMMARY

The Exhibitor's responsibility can be summed up as simply: **"Be a good neighbor!"** All exhibitors are equal regardless of size and should be given an equal opportunity, within reason, to present their product in the most effective manner to the audience.

STANDARD BOOTH

Linear Booths have only one side exposed to an aisle and are generally arranged in a series along a straight line. They are also called "in-line" booths.

Dimensions: Linear Booths are most commonly ten feet (10') wide and ten feet (10') deep, i.e. 10'x10'. A maximum back wall height limitation of height feet (8') is generally specified.

Use of Space: Regardless of the number of Linear Booths utilized, (e.g. 10'x20', 10'x30', 10'x40', etc.) Display materials should be arranged in such a manner so as not to obstruct sight lines of neighboring exhibitors.

The maximum height of eight feet (8') is allowed only in the rear half of the booth space, with a four-foot (4') height restriction imposed on all materials in the remaining space forward to the aisle.

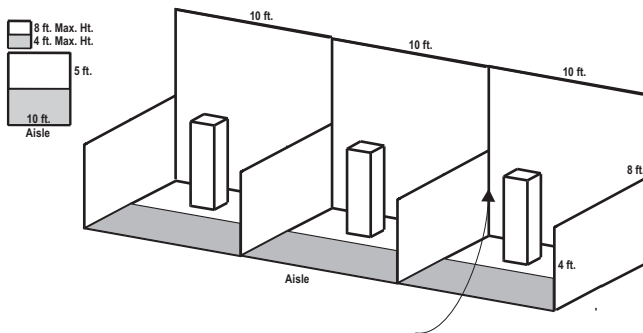

One or more standard 10'x10' units in a straight line.

Note: Booth drape is set at 8 ft max.

Display fixtures over 4 ft high must be confined to that area that is at least 5 ft from the aisle line.

PENINSULA END-CAP BOOTH

An end cap booth is exposed to aisles on three sides and composed of two booths.

Dimensions: End-cap Booths are generally ten feet (10') deep by twenty feet (20') wide. The maximum back wall height of eight feet (8') is allowed only in the rear half of the booth space and within five feet (5') of the two side aisles with a four foot (4') height restriction imposed on all materials in the remaining space forward to the aisle.

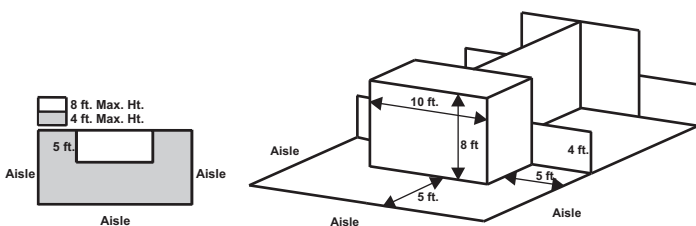

HANGING SIGN BOOTH

An exhibit component suspended above an exhibit of four or more standard units back-to-back with an aisle on at least three sides for the purpose of displaying graphics or identification.

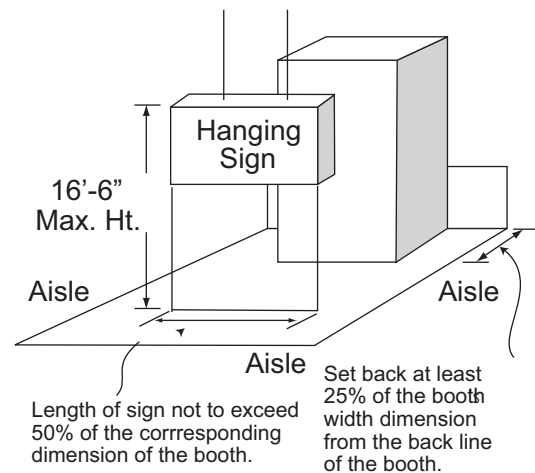

****All overhead hanging must be assembled, installed, and removed by the official service provider****

ISLAND BOOTH

An Island Booth is any size booth exposed to aisles on all four sides.

Dimensions: An Island Booth is 20'x30' or larger, although it may be configured differently.

Use of Space: The entire cubic content of the space may be used up to the maximum allowable height, which is usually sixteen feet (16'), including signage.

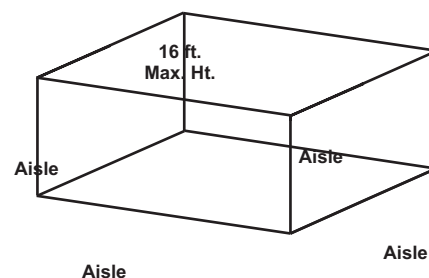

Please note that the ceiling height in the Exhibit Hall is 25 feet.



Fax: 253 437 0032
 14900 Interurban Avenue South, Suite 271
 Seattle, WA
 USA 98168
 Telephone: 253 437 0031
 E-mail: operations@levyexpo.com

**50th Annual Regional Anesthesiology and
 Acute Pain Medicine Meeting**
 May 1 - 3, 2025
 Rosen Shingle Creek
 Orlando, FL

THIRD PARTY BILLING REQUEST

COMPANY	BOOTH NUMBER	Deadline Date April 10, 2025
ADDRESS <small>street city state/province zip/postal code country</small>		
PHONE <small>FAX</small>	PURCHASE ORDER NUMBER	<i>All orders are regulated by LES Payment Terms & Conditions as well as Material Handling Terms & Conditions.</i>
AUTHORIZED CONTACT SIGNATURE X	AUTHORIZED CONTACT - PLEASE PRINT DATE	

You may arrange for a third party to handle your display and be billed for services. LES will agree to this arrangement if the third party has a satisfactory payment record with us. BOTH firms must complete this form, and the **THIRD PARTY must complete the credit card charge authorization on the *Payment & Credit Card Authorization form***. Return both forms by the deadline date.

It is understood and agreed that the exhibiting firm is ultimately responsible for payment of charges. If your named third party does not pay the invoice before the last day of the show, charges will revert to you, the exhibiting firm. All invoices are due and payable upon receipt.

EXHIBITING FIRM

EXHIBITING FIRM _____

ADDRESS _____

CITY STATE/PROVINCE ZIP/POSTAL CODE _____

PHONE FAX _____

AUTHORIZED SIGNATURE _____

THIRD PARTY

THIRD PARTY _____

ADDRESS _____

CITY STATE/PROVINCE ZIP/POSTAL CODE _____

PHONE FAX _____

AUTHORIZED SIGNATURE _____

ALL LES SERVICES WILL BE INVOICED TO THE THIRD PARTY UNLESS INDICATED BELOW:

EXHIBITING FIRM'S CREDIT CARD CHARGE AUTHORIZATION

CARDHOLDER'S BILLING ADDRESS

CITY PROV. / STATE _____

POSTAL/ZIP CODE COUNTRY _____

TODAY'S DATE MONTH / DAY / YEAR

CARD NUMBER

VISA MASTERCARD AMEX CHECK

EXPIRY DATE CVCC

CARDHOLDER NAME
(PLEASE PRINT)

SIGNATURE _____



Fax: 253 437 0032
 14900 Interurban Avenue South, Suite 271
 Seattle, WA
 USA 98168
 Telephone: 253 437 0031
 E-mail: operations@levyexpo.com

**50th Annual Regional Anesthesiology and
 Acute Pain Medicine Meeting**
 May 1 - 3, 2025
 Rosen Shingle Creek
 Orlando, FL

PAYMENT & CREDIT CARD CHARGE AUTHORIZATION FORM

COMPANY				BOOTH NUMBER			
ADDRESS		street	city	state/province	zip/postal code	country	
PHONE	FAX	PO #		E-MAIL			
AUTHORIZED CONTACT SIGNATURE X				AUTHORIZED CONTACT - PLEASE PRINT		DATE	

All orders are regulated by LES Payment Terms & Conditions as well as Material Handling Terms & Conditions.

CREDIT CARD AUTHORIZATION

<input type="checkbox"/> VISA		<input type="checkbox"/> MASTERCARD		<input type="checkbox"/> AMERICAN EXPRESS		EXPIRY DATE			CCVC				
ACCOUNT NUMBER													<input type="checkbox"/> CORPORATE <input type="checkbox"/> PERSONAL
CARDHOLDER'S BILLING ADDRESS				city	state/province	zip/postal code	country						
CARDHOLDER'S SIGNATURE X				CARDHOLDER'S NAME - PLEASE PRINT									

Please complete the REQUIRED order forms and submit with Payment & Credit Card Authorization Form and full payment. You may choose to pay by credit card and/or bank check, however, **we require your credit card authorization to be on file with LES.** For your convenience, we will use this authorization to charge your credit card for any additional amounts incurred as a result of show site orders placed by your representative for this event.

CALCULATION OF ORDER FORMS

TOTAL FROM EACH ORDER FORM

Carpet, Drape & Complements Rental Order Form.....	\$	
Custom Carpet Order Form.....	\$	
Table and Chair Rental Order Form.....	\$	
Specialty Accessories Order Form.....	\$	
Rental Exhibits Order Form.....	\$	
Cabinets Order Form.....	\$	
Graphics & Sign Order Form.....	\$	
In-Booth Forklift Order Form.....	\$	
Exhibit Booth Cleaning Order Form.....	\$	
Labor Order Form.....	\$	
Material Handling Order Form.....	\$	
FULL PAYMENT IN US FUNDS	\$	

To simplify payment, send one check payable to Levy Exposition Services Inc. for the entire amount or note the amount to be charged to your credit card.

Charge my credit card in the amount of \$

Check no. Dated in the amount of \$

CARPET and DRAPE

Standard carpet color options



Blue

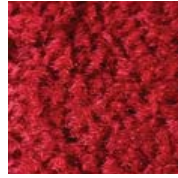

Red

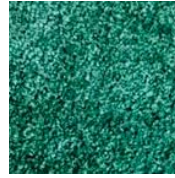

Teal



Grey



Burgundy



Purple

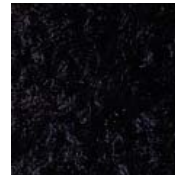

Black

Drape color options

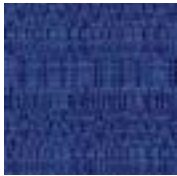

Blue



Red

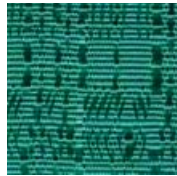

Teal



White

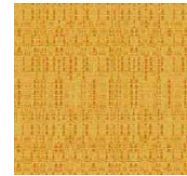

Gold



Black



Purple

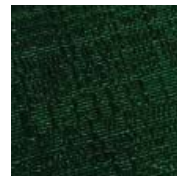

Green

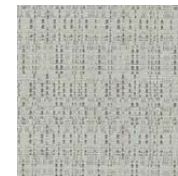

Grey



Burgundy

**DISCLAIMER* Actual products and colors available may vary from the images shown. All products subject to availability*

Do you have questions?

We would be pleased to help. Contact us at: 253 437 0031

operations@levyexpo.com

www.levyexpo.com



Fax: 253 437 0032
 14900 Interurban Avenue South, Suite 271
 Seattle, WA
 USA 98168
 Telephone: 253 437 0031
 E-mail: operations@levyexpo.com

50th Annual Regional Anesthesiology and
 Acute Pain Medicine Meeting
 May 1 - 3, 2025
 Rosen Shingle Creek
 Orlando, FL

CARPET, DRAPE & COMPLEMENTS RENTAL ORDER FORM & INVOICE

COLORED CARPET SELECTIONS

Description	Discount Rate	Standard Rate	Total
Size - 10 ft. X 10 ft.	325.00	405.00	
10 ft. X 20 ft.	650.00	810.00	
10 ft. X 30 ft.	975.00	1,215.00	
10 ft. X 40 ft.	1,300.00	1,620.00	
Custom cut size. Calculate sq. ft. x price per sq. ft. Size _____ ft. x _____ ft. = _____ sq. ft.	4.65	6.05	

Blue Red Teal Grey Burgundy Purple Black

DRAPE (Includes installation and removal)

_____ lin. ft. of 3' high drape	\$8.75/ft	\$11.35/ft	
_____ lin. ft. of 8' high drape	\$11.05/ft	\$14.73/ft	

Blue Red Teal White Gold Black
 Purple Green Grey Burgundy

PLEASE NOTE: THE DRAPE PROVIDED WITH YOUR BOOTH SPACE CANNOT BE CHANGED WITHOUT SHOW MANAGEMENT APPROVAL.

CARPET OPTIONS

Description	Discount Rate	Standard Rate	Total
Carpet foam padding per sq. ft. Size _____ ft. x _____ ft. = _____ sq. ft.	2.25	2.93	
Poly covering per sq. ft. Size _____ ft. x _____ ft. = _____ sq. ft.	1.00	1.30	

COMPLEMENTS (Also see Specialty Accessories Form)

Quantity	Description	Discount Rate	Standard Rate	Total
	Waste basket	27.00	35.10	
	Chrome coat tree	120.00	156.00	
	Aluminum easel	60.00	78.00	
	Chrome sign holder 22" X 28"	140.00	182.60	
	Chrome stanchions	35.00	45.50	
	Velvet stanchion ropes - blue	35.00	45.50	

SPECIAL INSTRUCTIONS

EXHIBITOR INFORMATION

COMPANY _____

CONTACT _____

BOOTH#

COST SUMMARY

RATE ADJUSTMENT	(OFFICE USE ONLY)	
25% CANCELLATION FEE	(OFFICE USE ONLY)	
SUBTOTAL		
6.5% SALES TAX		
TOTAL	US DOLLARS	

PLEASE REFER TO THE PAYMENT & CREDIT CARD CHARGE AUTHORIZATION FORM

ORDERS WILL NOT BE PROCESSED WITHOUT PAYMENT

STANDARD RATE will be applied to all orders not received and paid in full by **April 10, 2025**. We reserve the right to adjust orders calculated incorrectly.

A 25% CANCELLATION FEE will be applied to all orders received and then canceled. If full service has been provided then 100% of original fee will be applied.

CUSTOM CARPET

Deluxe Decorator 28oz. Carpet color options



Black



Red



Nu Blue



Silver Cloud



Beige



Charcoal



Key Lime

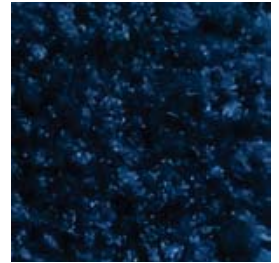

Navy



Cobalt



White

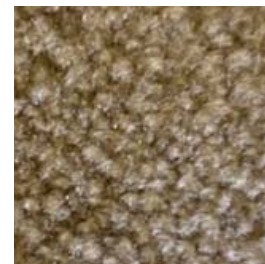

Silky Beige

**DISCLAIMER* Actual products and colors available may vary from the images shown. All products subject to availability*

Do you have questions?

We would be pleased to help. Contact us at: 253 437 0031

operations@levyexpo.com

www.levyexpo.com

CUSTOM CARPET ORDER FORM

Deluxe 28 oz. Carpet in a Variety of Decorator Colors to Enhance Your Exhibit

- | | | |
|---------------------------------------|--------------------------------------|-----------------------------------|
| <input type="checkbox"/> Black | <input type="checkbox"/> Red | <input type="checkbox"/> Nu Blue |
| <input type="checkbox"/> Silver Cloud | <input type="checkbox"/> Beige | <input type="checkbox"/> Charcoal |
| <input type="checkbox"/> Key Lime | <input type="checkbox"/> Navy | <input type="checkbox"/> Cobalt |
| <input type="checkbox"/> White | <input type="checkbox"/> Silky Beige | |

(CHECK BOX OF COLOR DESIRED)
 SAMPLES AVAILABLE UPON REQUEST

Rental includes installation and poly covering for protection and removal.
 Orders must be received by **April 10, 2025** to guarantee availability.

	DISCOUNT PRICE	STANDARD PRICE (late order)
Booth Size ____ ft. x ____ ft. = ____ sq. Ft. at	\$7.25 per sq. ft.	\$9.43 per sq. ft. =\$ ____
Carpet Pad ____ ft. x ____ ft. = ____ sq. Ft. at	\$2.25 per sq. ft.	\$2.93 per sq. ft. =\$ ____

NOTE: Include a floor plan if additional carpet is required to cover steps, skids and display fixtures. A quotation will be forwarded to you before we proceed

SPECIAL INSTRUCTIONS

EXHIBITOR INFORMATION

COMPANY	
CONTACT	BOOTH#

COST SUMMARY

RATE ADJUSTMENT	(OFFICE USE ONLY)	
CANCELLATION FEE	(OFFICE USE ONLY)	
SUBTOTAL		
6.5% SALES TAX		
TOTAL US DOLLARS		

PLEASE REFER TO THE PAYMENT & CREDIT CARD CHARGE AUTHORIZATION FORM

ORDERS WILL NOT BE PROCESSED WITHOUT PAYMENT

<p>STANDARD RATE will be applied to all orders not received and paid in full by April 10, 2025. We reserve the right to adjust orders calculated incorrectly.</p>	<p>A 25% CANCELLATION FEE will be applied to all orders received then canceled. If full service has been provided then 100% of original fee will be applied.</p>
---	---

TABLES & CHAIRS

Tables

All tables are available in the below options:

- Unskirted or Skirted
- 30" or 40" height
- 4', 6', or 8' lengths x 2' widths



4' x 2' skirted table



6' x 2' skirted table



8' x 2' skirted table

Skirt color options



Blue



Red



Black



Teal



Burgundy



Gold

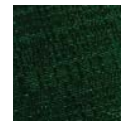

Green



Grey



Purple



White

Pedestal Tables

All pedestal tables are available in the below options:

- 30" diameter tops
- 30" or 40" high



40" high pedestal



30" high pedestal

Chairs



Fabric Sled Base Chair



Fabric Arm Chair



Fabric Highback Stool

**DISCLAIMER* Actual products and colors available may vary from the images shown. All products subject to availability*

Do you have questions?

We would be pleased to help. Contact us at: 253 437 0031

operations@levyexpo.com

www.levyexpo.com

TABLE AND CHAIR RENTAL ORDER FORM & INVOICE

TABLES

Description	Qty.	Discount Rate	Standard Rate	Total
TABLES 30" HEIGHT				
8' x 2' Skirted		265.00	315.00	
6' x 2' Skirted		225.00	275.00	
4' x 2' Skirted		215.00	255.00	
Fourth side of table skirted		72.00	93.60	
Unskirted table <input type="checkbox"/> 8' <input type="checkbox"/> 6' <input type="checkbox"/> 4'		88.00	114.40	
<input type="checkbox"/> Blue <input type="checkbox"/> Red <input type="checkbox"/> Black <input type="checkbox"/> Teal <input type="checkbox"/> Burgundy <input type="checkbox"/> Gold <input type="checkbox"/> Green <input type="checkbox"/> Grey <input type="checkbox"/> Purple <input type="checkbox"/> White				

Description	Qty.	Discount Rate	Standard Rate	Total
TABLES 40" COUNTER HEIGHT				
8' x 2' Skirted		295.00	355.00	
6' x 2' Skirted		270.00	330.00	
4' x 2' Skirted		245.00	295.00	
Fourth side of table skirted		78.00	104.40	
Unskirted table <input type="checkbox"/> 8' <input type="checkbox"/> 6' <input type="checkbox"/> 4'		98.00	127.40	
<input type="checkbox"/> Blue <input type="checkbox"/> Red <input type="checkbox"/> Black <input type="checkbox"/> Teal <input type="checkbox"/> Burgundy <input type="checkbox"/> Gold <input type="checkbox"/> Green <input type="checkbox"/> Grey <input type="checkbox"/> Purple <input type="checkbox"/> White				

Description	Qty.	Discount Rate	Standard Rate	Total
PEDESTAL TABLE 30" DIAMETER				
30" Table height		179.00	232.70	
40" Counter height		219.00	284.70	

SPECIAL INSTRUCTIONS

EXHIBITOR INFORMATION

COMPANY _____

CONTACT _____ **BOOTH#** _____

COST SUMMARY

RATE ADJUSTMENT	(OFFICE USE ONLY)	
CANCELLATION FEE	(OFFICE USE ONLY)	
SUBTOTAL		
6.5% SALES TAX		
TOTAL US DOLLARS		





PLEASE REFER TO THE PAYMENT & CREDIT CARD CHARGE AUTHORIZATION FORM
 ORDERS WILL NOT BE PROCESSED WITHOUT PAYMENT

STANDARD RATE will be applied to all orders not received and paid in full by **April 10, 2025**. We reserve the right to adjust orders calculated incorrectly.



A 25% CANCELLATION FEE will be applied to all orders received and then canceled. If full service has been provided then 100% of original fee will be applied.

SPECIALTY ACCESSORIES RENTAL ORDER FORM & INVOICE

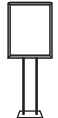
DISPLAY UNITS

Description	Qty.	Discount Rate	Standard Rate	Total
 FABRIC POSTER BOARD 4' x 8' grey fabric covered both sides <input type="checkbox"/> Horizontal (shown) <input type="checkbox"/> Vertical		144.00	187.00	
 BLACK UPRIGHT LITERATURE RACK 6 pockets for 8.5" x 11" material		160.00	208.00	
 PLEXIGLASS BROCHURE HOLDER 9" x 11" <input type="checkbox"/> Table top <input type="checkbox"/> Wall mount		46.00	59.80	
 ALUMINUM EASEL Fits sign sizes: 22" x 28" 24" x 36" 28" x 44"		60.00	78.00	
 CHROME SIGN HOLDER 22" x 28"		140.00	182.60	

ACCESSORIES

 <input type="checkbox"/> CHROME CLOTHING STAND <input type="checkbox"/> CHROME BAG HOLDER		120.00	156.00	
 CHROME COAT TREE		120.00	156.00	

SPECIAL INSTRUCTIONS

EXHIBITOR INFORMATION

COMPANY

CONTACT

BOOTH#

COST SUMMARY

RATE ADJUSTMENT	(OFFICE USE ONLY)	
25% CANCELLATION FEE	(OFFICE USE ONLY)	
SUBTOTAL		
6.5% SALES TAX		
TOTAL	US DOLLARS	

PLEASE REFER TO THE PAYMENT & CREDIT CARD CHARGE AUTHORIZATION FORM

****ORDERS WILL NOT BE PROCESSED WITHOUT PAYMENT****

STANDARD RATE will be applied to all orders not received and paid in full by **April 10, 2025**. We reserve the right to adjust orders calculated incorrectly.

A 25% CANCELLATION FEE will be applied to all orders received and then canceled. If full service has been provided then 100% of original fee will be applied.

RENTAL EXHIBITS

10' x 10' Hardwall Rental Exhibit Booths

All hardwall packages include the below:

- Aluminum structure
- White
- Header(s) - block letters - black (logo extra)
- 10' x 10' Carpet
- 30" pedestal table (x1)
- Fabric sledbase chairs (x2)

Package A1 Base



Package A2 Deluxe

- Base Package plus the below:
- 10" deep shelves (x2)
- 39" x 20" x 39" counter (x1)

Package B1 Base

- Curved header - block letters - black (logo extra)
- Curved front display counter



Package B2 Deluxe

- Base Package plus the below:
- Enclosed corner counter
- 10" deep shelves (x2)

Package C1 Base



Package C2 Deluxe

- Base Package plus the below:
- 10" deep shelves (x2)
- 39" x 20" x 39" counter (x1)

Package D1 Base

- Oversized header - block letters - black (logo extra)
- 20" x 39" x 39" high built-in counters on backwall (x2)



Package D2 Deluxe

- Base Package plus the below:
- 10" deep shelves (x2)
- 39" x 20" x 39" counter (x1)

**DISCLAIMER* Actual products and colors available may vary from the images shown. All products subject to availability*

Do you have questions?

We would be pleased to help. Contact us at: 253 437 0031

operations@levyexpo.com

www.levyexpo.com

RENTAL EXHIBITS

10' x 20' Hardwall Rental Exhibit Booths

All hardwall packages include the below:

- Aluminum structure
- White
- Header(s) - block letters - black (logo extra)
- 10' x 20' Carpet
- 30" pedestal table (x1)
- Fabric sledbase chairs (x2)

Package E1 Base

- Straight headers (x2)



Package E2 Deluxe

- Base Package plus the below:
- 10" deep shelves (x2)
- 39" x 20" x 39" counter (x1)



Package F1 Base

- Straight header (x1)
- Angled header (x2)
- Storage area with drape door
- Front built-in corner counters (x2)



Package F2 Deluxe

- Base Package plus the below:
- Lockable door for storage area
- 39" x 20" x 39" counter (x2)



Package G1 Base

- Straight header (x1)
- 39" x 20" x 39" built-in counter (x1)



Package G2 Deluxe

- Base Package plus the below:
- 10" deep shelves (x4)



Package H1 Base

- Oversized curved header (x1)
- 39" x 20" x 39" built-in counters (x3)



Package H2 Deluxe

- Base Package plus the below:
- 10" deep shelves (x3)
- 2m curved front counter (x1)



**DISCLAIMER* Actual products and colors available may vary from the images shown. All products subject to availability*

Do you have questions?

We would be pleased to help. Contact us at: 253 437 0031

operations@levyexpo.com

www.levyexpo.com



Fax: 253 437 0032
 14900 Interurban Avenue South, Suite 271
 Seattle, WA
 USA 98168
 Telephone: 253 437 0031
 E-mail: operations@levyexpo.com

**50th Annual Regional Anesthesiology and
 Acute Pain Medicine Meeting**
 May 1 - 3, 2025
 Rosen Shingle Creek
 Orlando, FL

RENTAL EXHIBITS RENTAL ORDER FORM & INVOICE

10' x 10' BOOTH PACKAGES - *Please contact customer service for GRAPHIC UPGRADES*

Description: Base package includes: Aluminum structure, white hardwalls, booth header with company name in block lettering, carpet, 30" pedestal table, (2) fabric chairs, installation and dismantle.	Qty	Discount Rate	Standard Rate	Total
PACKAGE A1 Basic - Base package with header		4,360.00	5,668.00	
PACKAGE A2 Deluxe - Base package + (2) 10" deep shelves, (1) 39" x 20" x 39" counter		4,710.00	6,123.00	
PACKAGE B1 Basic - Corner base package booth with curved counter, 1 curved header sign		4,840.00	6,292.00	
PACKAGE B2 Deluxe - Base package + enclosed corner counter, (2) 10" deep shelves		5,110.00	6,643.00	
PACKAGE C1 Basic - Base package with header		4,500.00	5,850.00	
PACKAGE C2 Deluxe - Base package + (2) 10" deep shelves, (1) 39" x 20" x 39" counter		5,050.00	6,565.00	
PACKAGE D1 Basic - Base package with oversized header, (2) built-in back counters		5,240.00	6,812.00	
PACKAGE D2 Deluxe - Base package + (2) 10" deep shelves, (1) 39" x 20" x 39" counter		5,480.00	7,124.00	

10' x 20' BOOTH PACKAGES - *Please contact customer service for GRAPHIC UPGRADES*

Description: Base package includes: Aluminum structure, white hardwalls, booth header with company name in block lettering, carpet, 30" pedestal table, (2) fabric chairs, installation and dismantle.	Qty	Discount Rate	Standard Rate	Total
PACKAGE E1 Basic - Base package with headers		7,290.00	9,477.00	
PACKAGE E2 Deluxe - Base package + (2) 10" deep shelves, (1) 39" x 20" x 39" counter		7,931.00	10,310.00	
PACKAGE F1 Basic - Base package with headers, storage and drape door, (2) built-in counters		7,815.00	10,159.00	
PACKAGE F2 Deluxe - Base package + lockable door for storage, (2) 39" x 20" x 39" counters		8,775.00	11,407.00	
PACKAGE G1 Basic - Base package with header, (1) built-in counter		8,280.00	10,764.00	
PACKAGE G2 Deluxe - Base package + (2) 10" deep shelves		8,744.00	11,368.00	
PACKAGE H1 Basic - Base package with oversized curved header, (3) built-in back counters		9,270.00	12,051.00	
PACKAGE H2 Deluxe - Base package + (2) 10" deep shelves, (1) curved front counter		9,994.00	12,992.00	

OPTIONS & INFORMATION

HARDWALL PANEL (non fabric) SELECTION

White

CARPET COLOR SELECTIONS

Grey Red Teal Blue Black Burgundy Purple

HEADER TO READ (up to 20 characters, black lettering on white)

Header One

Header Two

ACCESSORY OPTIONS

Description	Qty.	Discount Rate	Standard Rate	Total
1 meter Angled Shelves		80.00	104.00	
1 meter Shelves		70.00	91.00	
Spot Lights (For use with rental unit)		90.00	117.00	
Literature Pockets 8 1/2" x 11"		40.00	52.00	
Nylon Loop Fabric Panel per sq.ft. <small>**contact for available color options</small>		\$5.25 sq.ft.	6.83 sq.ft.	

SPECIAL INSTRUCTIONS

EXHIBITOR INFORMATION

COMPANY

CONTACT

BOOTH#

COST SUMMARY

RATE ADJUSTMENT	(OFFICE USE ONLY)	
25% CANCELLATION FEE	(OFFICE USE ONLY)	
SUBTOTAL		
6.5% SALES TAX		
TOTAL	US DOLLARS	

PLEASE REFER TO THE PAYMENT & CREDIT CARD CHARGE AUTHORIZATION FORM

ORDERS WILL NOT BE PROCESSED WITHOUT PAYMENT

STANDARD RATE will be applied to all orders not received and paid in full by **April 10, 2025**. We reserve the right to adjust orders calculated incorrectly.

A 25% CANCELLATION FEE will be applied to all orders received and then cancelled 2 weeks prior to install. If full service has been provided then 100% of original fee will be applied.
 xpo21_rentalexhibits

CUSTOM EXHIBITS

A more sophisticated technique to exhibit marketing messages creatively and effectively!

With decades of service, Levy continues to provide viable and reliable alternatives to maximize clients' overall booth space. Our sales team and design specialists work closely with each and every client to create a unique exhibit designed to meet a wide variety of today's marketing strategies. Whether the image and budget are conservative or extravagant Levy exceeds to offer the most suitable and perfect space solutions.



Collaboratively designed to meet your specific requirements, budget, and bring your vision to reality.

Each Levy Custom Designed Exhibit will be built to exact specifications and will be:

- Unique
- Attractive
- Versatile
- Impressive
- Memorable
- Functional
- Creative
- Inviting
- Efficient

Let us help you create a one of a kind booth space.

Call our experienced professionals for an innovative, customized, and no obligation approach.



CABINETS

Straight Cabinets

All straight cabinets come with sliding doors. Optional Upgrades noted below:

- Lock for doors
- Lighting
*Jewelry Case or Show Case
- Branding - graphic panels



Cabinet "A"

1 meter cabinet with doors
39" long x 20" deep x 40" high



Cabinet "B"

1 meter Jewelry Case with doors
39" long x 20" deep x 40" high



Cabinet "C"

1 meter Show Case with doors
39" long x 20" deep x 40" high



Cabinet "D"

2 meter cabinet with doors
80" long x 20" deep x 40" high

Curved Cabinets

Optional Upgrades noted below:

- Lock for doors
- Branding - graphic panels



Cabinet "E"

1 meter curved cabinet
61" long x 20" deep x 40" high

Cabinet "F"

1 meter curved cabinet with door
61" long x 20" deep x 40" high

**Same as cabinet "E" but with door

**DISCLAIMER* Actual products and colors available may vary from the images shown. All products subject to availability*

Do you have questions?

We would be pleased to help. Contact us at: 253 437 0031

operations@levyexpo.com

www.levyexpo.com

CABINETS ORDER FORM & INVOICE

STYLE	DESCRIPTION	QTY	DISCOUNT RATE	STANDARD RATE	TOTAL
CABINET "A"	1 meter Cabinet with doors <input type="checkbox"/> Lock (\$20.00 each)		695.00	904.00	
	Cabinet with + custom graphic panel <input type="checkbox"/> Lock (\$20.00 each)		880.00	1,144.00	
CABINET "B"	1 meter Jewelry Case with doors <input type="checkbox"/> Lock (\$20.00 each) <input type="checkbox"/> Lights (\$20.00 each)		830.00	1,079.00	
	Jewelry Case + custom graphic panel <input type="checkbox"/> Lock (\$20.00 each) <input type="checkbox"/> Lights (\$20.00 each)		970.00	1,261.00	
CABINET "C"	1 meter Show Case with doors <input type="checkbox"/> Lock (\$20.00 each) <input type="checkbox"/> Lights (\$20.00 each)		960.00	1,248.00	
	Show Case + custom graphic panel <input type="checkbox"/> Lock (\$20.00 each) <input type="checkbox"/> Lights (\$20.00 each)		1,030.00	1,339.00	
CABINET "D"	2 meter Cabinet with doors <input type="checkbox"/> Lock (\$20.00 each)		980.00	1,274.00	
	2 meter Cabinet + custom graphic panel <input type="checkbox"/> Lock (\$20.00 each)		1,370.00	1,781.00	
CABINET "E"	1 meter Curved cabinet (open back)		860.00	1,118.00	
	Curved cabinet + custom graphic panel		1,120.00	1,456.00	
CABINET "F"	1 meter Curved cabinet with doors <input type="checkbox"/> Lock (\$20.00 each)		940.00	1,222.00	
	Curved cabinet w/ doors + custom graphic panel		1,205.00	1,567.00	

NOTE: Should you wish to have a graphic panel upgrade for your cabinet, please contact our Operations department to confirm details on graphic file submission.

EXHIBITOR INFORMATION	
COMPANY	
CONTACT	BOOTH#

COST SUMMARY		
RATE ADJUSTMENT	(OFFICE USE ONLY)	
CANCELLATION FEE	(OFFICE USE ONLY)	
SUBTOTAL		
6.5% SALES TAX		
TOTAL US DOLLARS		

PLEASE REFER TO THE PAYMENT & CREDIT CARD CHARGE AUTHORIZATION FORM
 ORDERS WILL NOT BE PROCESSED WITHOUT PAYMENT

STANDARD RATE will be applied to all orders not received and paid in full by **April 10, 2025**. We reserve the right to adjust orders calculated incorrectly.

A 25% CANCELLATION FEE will be applied to all orders received and then cancelled. If full service has been provided then 100% of original fee will be applied.

GRAPHICS AND SIGN ORDER FORM & INVOICE

STANDARD SIGN SIZES

Quantity	Description	Discount Rate	Standard Rate	Total
	7" x 11"	41.00	53.00	
	7" x 44"	48.00	62.00	
	11" x 14"	58.00	75.00	
	14" x 22"	73.00	95.00	
	22" x 28"	92.00	120.00	
	28" x 44"	138.00	179.00	

Prices listed are for one-color copy (up to 10 words) on a white background.

OPTIONAL SERVICES

Quantity	Description	Discount Rate	Standard Rate	Total
	Over 10 words (Add per word)	3.62	4.70	
	Easel back on sign (Up to 22" x 28")	4.83	6.23	
	Logo sign	Quoted on Request		
	Banner	Quoted on Request		

DIGITAL GRAPHICS (6 SQ FT MINIMUM)

- Digital files must be provided to LES specifications.
- Graphics should be sent in vector format as .eps files.
 Also acceptable: Adobe Illustrator (.ai) & Corel Draw (.cdr) files
- Photographic & Pixel based complex graphics must be MINIMUM 100 dpi at actual output size.
 Acceptable formats include: .tif, .bmp, & Adobe Photoshop & Corel Photo Paint files
- All text **MUST** be outlined / converted to curves, or fonts included with image files.
- Art work is to be received as file ready.
- Editing & Design time is charged at a rate of \$75.00 per hour (1 hour minimum).
- Digital files must be received at least three (3) weeks before show to receive discount price.

Quantity	Description	Discount Rate	Standard Rate	Total
	Digital Prints per sq.ft. (Mounted on Foamcore w/ Matte Laminat)	\$19.50	\$29.00	

EXHIBITOR INFORMATION

COMPANY _____

CONTACT _____ **BOOTH#** _____

INDICATE YOUR SIGN COPY HERE

ADDITIONAL SERVICES & TERMS

If you would like us to provide more information and pricing on banners, logos, silk screening, special graphics or any other items please contact our Exhibits department for a complimentary consultation.

Orders required within 72 hours before show opening may be subject to a rush delivery charge. Please allow a minimum of 24 hours for any on-site sign orders.

CHOOSE YOUR LAYOUT

Levy Exposition Services Inc.
to design layout

Vertical Horizontal

LETTER COLOR SELECTIONS

Blue Red Green Teal Black Purple

Black lettering will be provided unless otherwise specified.

SPECIAL INSTRUCTIONS

COST SUMMARY

RATE ADJUSTMENT	(OFFICE USE ONLY)	
100% CANCELLATION FEE	(OFFICE USE ONLY)	
SUBTOTAL		
6.5% SALES TAX		
TOTAL	US DOLLARS	

PLEASE REFER TO THE PAYMENT & CREDIT CARD CHARGE AUTHORIZATION FORM
 ORDERS WILL NOT BE PROCESSED WITHOUT PAYMENT

STANDARD RATE will be applied to all orders not received and paid in full by **April 10, 2025**. We reserve the right to adjust orders calculated incorrectly.

A 100% CANCELLATION FEE will be applied to all orders received then cancelled.



Fax: 253 437 0032
 14900 Interurban Avenue South, Suite 271
 Seattle, WA
 USA 98168
 Telephone: 253 437 0031
 E-mail: operations@levyexpo.com

**50th Annual Regional Anesthesiology and
 Acute Pain Medicine Meeting**
 May 1 - 3, 2025
 Rosen Shingle Creek
 Orlando, FL

EXHIBIT BOOTH CLEANING ORDER FORM & INVOICE

SERVICES

OUR SERVICES INCLUDE THE FOLLOWING:

EXHIBIT VACUUMING

EMPTYING OF WASTEBASKETS

GENERAL HOUSEKEEPING

DISCOUNT RATE

TOTAL SQUARE FEET OF BOOTH SPACE	DAYS REQUIRED	RATE	TOTAL
<input type="checkbox"/> Prior To Show Opening <input type="checkbox"/> After First Day <input type="checkbox"/> After Second Day <input type="checkbox"/> After Third Day			
_____	X _____	X \$0.88 =	_____
100 Square Feet Minimum Order	Total Number of Days		

STANDARD RATE & ON-SITE ORDERS

TOTAL SQUARE FEET OF BOOTH SPACE	DAYS REQUIRED	RATE	TOTAL
<input type="checkbox"/> Prior To Show Opening <input type="checkbox"/> After First Day <input type="checkbox"/> After Second Day <input type="checkbox"/> After Third Day			
_____	X _____	X \$1.05 =	_____
100 Square Feet Minimum Order	Total Number of Days		

ADDITIONAL INFORMATION

General vacuuming of the show floor aisles is provided, however, cleaning of your exhibit area is not included in your exhibit space rental.

If you have any questions or need assistance with any items not listed, please contact our exhibits department.

All carpets ordered from us are installed clean for your use. However, you may order cleaning services for debris created during set-up and show hours.

A surcharge may be applied for any damage and or staining of exhibit space.

SPECIAL INSTRUCTIONS

Please indicate on the lines below any special cleaning requests or instructions you may have.

EXHIBITOR INFORMATION

COMPANY

CONTACT

BOOTH#

COST SUMMARY

RATE ADJUSTMENT	(OFFICE USE ONLY)	
25% CANCELLATION FEE	(OFFICE USE ONLY)	
SUBTOTAL		
TOTAL	US DOLLARS	

PLEASE REFER TO THE PAYMENT & CREDIT CARD CHARGE AUTHORIZATION FORM

ORDERS WILL NOT BE PROCESSED WITHOUT PAYMENT

STANDARD RATE will be applied to all orders not received and paid in full by **April 10, 2025**. We reserve the right to adjust orders calculated incorrectly.

A 25% CANCELLATION FEE will be applied to all orders received then canceled. If full service has been provided then 100% of original fee will be applied.



Fax: 253 437 0032
 14900 Interurban Avenue South, Suite 271
 Seattle, WA
 USA 98168
 Telephone: 253 437 0031
 E-mail: operations@levyexpo.com

**50th Annual Regional Anesthesiology and
 Acute Pain Medicine Meeting**
 May 1 - 3, 2025
 Rosen Shingle Creek
 Orlando, FL

IN-BOOTH FORKLIFT ORDER FORM & INVOICE

TERMS & CONDITIONS

The exhibitor, his agent or representative must supply sufficient manpower including competent and authorized supervisors to manage and control the exhibit installation activity.

The exhibitor, upon signing this order form, covenants and agrees to indemnify and hold harmless Levy Exposition Services Inc., from and against all claims, demands, charges, losses or damage arising or alleged to arise directly or indirectly or incidentally by person of any act omission or operations of the exhibitor, his agent or representative, their officers, employees, agents or anyone for whom the exhibitor, his agent or representative are legally responsible. Levy Exposition Services Inc., is to be cross insured on the insurance for the exhibitor's, his agent's or representative's operations conducted at this event. Evidence of the insurance described above shall be forwarded to Levy Exposition Services Inc.

THIS SERVICE IS NOT PROVIDED BY SHOW MANAGEMENT

RATES

DESCRIPTION	STANDARD RATE	
STRAIGHT TIME 8:00 AM - 4:30 PM Monday to Friday (Includes 5000 lb. Forklift and operator)	\$260.00 per Hour	
STRAIGHT TIME 8:00 AM - 4:30 PM Monday to Friday (Foreman)	\$155.00 per Hour	
OVERTIME 4:30 PM - 8:00 AM Monday to Friday, (Includes 5000 lb Forklift and operator) All day Saturday, Sunday, and holidays	\$380.00 per Hour	
OVERTIME 4:30 PM - 8:00 AM Monday to Friday, (Foreman) All day Saturday, Sunday, and holidays	\$235.00 per Hour	

ESTIMATED INSTALLATION REQUIREMENTS

DESCRIPTION	STANDARD RATE	TOTAL	There is a minimum charge of one (1) hour per forklift. Additional time thereafter is charged in one-half (½) hour increments. Date Required _____ Start Time _____
STRAIGHT TIME _____ Forklift _____ Hours	\$260.00 per Hour	\$_____ Total	
OVERTIME _____ Forklift _____ Hours	\$380.00 per Hour	\$_____ Total	

ESTIMATED DISMANTLE REQUIREMENTS

DESCRIPTION	STANDARD RATE	TOTAL	There is a minimum charge of one (1) hour per forklift. Additional time thereafter is charged in one-half (½) hour increments. Date Required _____ Start Time _____
STRAIGHT TIME _____ Forklift _____ Hours	\$260.00 per Hour	\$_____ Total	
OVERTIME _____ Forklift _____ Hours	\$380.00 per Hour	\$_____ Total	

EXHIBITOR INFORMATION

COMPANY _____

CONTACT _____ **BOOTH#** _____

COST SUMMARY

RATE ADJUSTMENT	(OFFICE USE ONLY)	
25% CANCELLATION FEE	(OFFICE USE ONLY)	
SUBTOTAL		
ADDITIONAL 25% LATE ORDER		
TOTAL	US DOLLARS	

***PLEASE ADD 25% FOR ORDERS PLACED AFTER
 APRIL 10, 2025.**

PLEASE REFER TO THE PAYMENT & CREDIT CARD CHARGE AUTHORIZATION FORM

ORDERS WILL NOT BE PROCESSED WITHOUT PAYMENT

A 25% CANCELLATION FEE will be applied to all orders received then canceled. Orders cancelled within 7 days of scheduled start date will be charged 100% of the original fee.



Fax: 253 437 0032
 14900 Interurban Avenue South, Suite 271
 Seattle, WA
 USA 98168
 Telephone: 253 437 0031
 E-mail: operations@levyexpo.com

50th Annual Regional Anesthesiology and
 Acute Pain Medicine Meeting
 May 1 - 3, 2025
 Rosen Shingle Creek
 Orlando, FL

LABOR ORDER FORM & INVOICE

SUPERVISION SERVICES (Please indicate desired service)

LEVY EXPOSITION SERVICES INC. SUPERVISED

MOVE IN MOVE OUT

LEVY EXPOSITION SERVICES INC. WILL SUPERVISE labor to unpack and install display before exhibitor arrival at show site and/or dismantle and pack display after show closing.

A 50% **Surcharge** will be added to the labor rates below for this professional supervision.

EXHIBITOR SUPERVISED

MOVE IN MOVE OUT

EXHIBITOR WILL SUPERVISE the laborers provided by Levy Exposition Services Inc. for the installation and/or dismantle of the exhibit.

Supervisor's name _____

Starting time can be guaranteed only when labor is requested for the start of the working day at 8 AM or 30 minutes after the start of move out. For all other starting times, check in at the **Exhibitor Service Desk** one-half (1/2) hour before time requested.

LABOR RATES

REGULAR TIME	8:00 AM - 4:30 PM Monday to Friday	\$155.00 per Hour
OVER TIME	Before 8:00 am and after 4:30 pm Monday to Friday, All day Saturday, Sunday, and holidays.	\$235.00 per Hour

ESTIMATED INSTALLATION REQUIREMENTS

REGULAR TIME	____ Laborers	____ Hours	\$155.00 per Hour	\$ _____ Total	A minimum charge for labor is one (1) hour per laborer. Labor thereafter is charged in one-half (1/2) hour increments. Date Required _____ Start Time _____
OVER TIME	____ Laborers	____ Hours	\$235.00 per Hour	\$ _____ Total	

ESTIMATED DISMANTLE REQUIREMENTS

REGULAR TIME	____ Laborers	____ Hours	\$155.00 per Hour	\$ _____ Total	A minimum charge for labor is one (1) hour per laborer. Labor thereafter is charged in one-half (1/2) hour increments. Date Required _____ Start Time _____
OVER TIME	____ Laborers	____ Hours	\$235.00 per Hour	\$ _____ Total	

INBOUND FREIGHT INFORMATION ****BE SURE TO COMPLETE THE OUTBOUND FORM AS WELL****

Carrier	Date Shipped	Pro Number
Number of Pieces	Weight	Arrival Date (Target)
<input type="checkbox"/> Loose Display <input type="checkbox"/> Crated Display		
Quantity of Ladders Required (Optional)		

EXHIBITOR INFORMATION

COMPANY	
CONTACT	BOOTH#

***PLEASE ADD 25% FOR ORDERS PLACED AFTER APRIL 10, 2025.**

COST SUMMARY

RATE ADJUSTMENT	(OFFICE USE ONLY)	
CANCELLATION FEE	(OFFICE USE ONLY)	
SUBTOTAL		
SUPERVISION 50%		
ADDITIONAL 25% LATE ORDER		
TOTAL	US DOLLARS	

PLEASE REFER TO THE PAYMENT & CREDIT CARD CHARGE AUTHORIZATION FORM
****ORDERS WILL NOT BE PROCESSED WITHOUT PAYMENT****

TERMS & CONDITIONS Gratuities in any form, including cash, gifts or labor hours for work not actually performed are prohibited. We reserve the right to adjust orders calculated incorrectly.

A 25% CANCELLATION FEE will be applied to all orders received then canceled. Orders cancelled within 7 days of scheduled start date will be charged 100% of the original fee.
 xpo21_labor

OUTBOUND SHIPPING INSTRUCTIONS - DISMANTLE LABOR

Exhibitor Name:	Tel. #:	Booth #
Billing Address:	Fax #:	
City / State / Zip:	Auth. by:	

1 Outbound Shipping Instructions

Please complete this section if Levy will be supervising dismantle booth labor:

*Exhibitor Outbound Shipping Instructions: At close of the show, exhibitor freight will be shipped to the address provided below.
 If your freight is being forwarded to another show, be sure to include the name of show and your booth number*

Company / Show: _____ **Booth #:** _____

Address: _____

City / State / Zip: _____

Attention: _____

Select Carrier

Ship via carrier of exhibitor's choice

Name of Carrier: _____

Ship via official show freight carrier

Select shipping method Ground Air **Select Service Provider:** _____

Please note:
 ■ The exhibitor is responsible for arranging either a carrier of their choice or the official show freight carrier to pick up at the close of the show.
 ■ Levy cannot guarantee pick up time for exhibitor appointed carriers. All shipments are moved out of the exhibit hall at Levy's discretion.

Please review the Quick Facts for the Carrier Check-in time

2 Billing Information

Please indicate billing information for carrier charges if different than above.

Bill Shipping Charges to (if different from above):

Shipper (signature): _____ **Shipper (print name):** _____

Freight Charges Billed To (Company/Show): _____

Address: _____

City / State / Zip: _____

Telephone: _____ **Attention:** _____

PAYMENT & LABOR

The terms and conditions set forth below become part of the contractual agreement between Levy Exposition Services Inc. and you, the EXHIBITOR. Acceptance of said terms and conditions will be construed when any of the following conditions are met:

- ~ **WHEN THE METHOD OF PAYMENT FORM IS SIGNED; OR**
- ~ **WHEN AN ORDER FOR LABOR, SERVICES, AND/OR RENTAL EQUIPMENT IS PLACED BY AN EXHIBITOR WITH LEVY EXPOSITION SERVICES INC.; OR**
- ~ **WHEN WORK IS PERFORMED ON BEHALF OF EXHIBITOR BY LABOR SECURED THROUGH LEVY EXPOSITION SERVICES INC.**

DEFINITIONS

"Levy Exposition Services Inc." ("LES"), and any sub-contractors affiliated within the show. The term EXHIBITOR shall be construed within the meaning of this contract as the EXHIBITOR and/or its employees, agents, representatives, and/or any Exhibitor Appointed Contractor (E.A.C.).

PAYMENT TERMS

Full payment, including any applicable tax, is due in advance or at show site. All payments must be in U.S. Funds and all checks must be drawn on a U.S. Bank. Orders received without advance payment or after the deadline date will incur additional [After Deadline] charges as indicated on each order form. All materials and equipment are on a rental basis for the duration of the show or event and remain the property of LES except where specifically identified as a sale. All LES rentals include delivery, installation and removal from EXHIBITOR's booth, unless stated otherwise. In case of cancellation, a one-hour "per person, per hour" charge will be applied to all labor, forklift and sign hanging orders that are not canceled in writing at least seven (7) days prior to the scheduled start time. If services have already been provided at the time of cancellation, 100% of original fee will be applied. It is EXHIBITOR'S responsibility to advise LES Exhibitor Services personnel of any problem with any order, and to check invoices for accuracy prior to the close of the exhibit. If EXHIBITOR is exempt from payment of sales tax, LES requires an exemption certificate for the State in which the services are to be used. Resale certificates are not valid unless EXHIBITOR is rebilling these charges to its customers. For International EXHIBITORS, LES requires 100% prepayment of advance orders, and any orders or services placed at show site must be paid at the show. For all others, should there be any pre-approved unpaid balance after the close of the show, terms will be net, due and payable in the UNITED STATES OF AMERICA, upon receipt of invoice. Effective 30 days after invoice date, any unpaid balance will bear a FINANCE CHARGE at the lesser of the maximum rate allowed by applicable law, or 1.5% per month, which is an ANNUAL PERCENTAGE RATE of 18%, and future orders will be on a pre-paid basis only. If any finance charge here under exceeds the maximum rate allowed by applicable law, the finance charge shall automatically be reduced to the maximum rate allowed, and any excess finance charge received by LES shall either be applied to reduce the principal unpaid balance or refunded to the payer. These payment terms and conditions shall be governed by and construed in accordance with the LAWS OF THE STATE OF FLORIDA. In the event of any dispute between EXHIBITOR and LES relative to any loss, damage, or claim, such EXHIBITOR shall not be entitled to and shall not withhold payment, or any partial payment, due to LES relative to any services, as an offset against the amount of any alleged loss or damage. Any claim against LES shall be considered a separate transaction, and shall be resolved on its own merits. LES reserves the right to charge EXHIBITOR for the difference between the EXHIBITOR's estimate of charges and the actual charges incurred by the EXHIBITOR, or for any charges that LES may be obligated to pay on behalf of the EXHIBITOR, including without limitation, any shipping charges.

LABOR PROVIDED UNDER THE SUPERVISION OF LES

RESPONSIBILITIES

LES shall be responsible for the performance of labor provided under this option. LES cannot assume responsibility for any acts of, or loss to, persons, parties and/or other contracting firms not under LES's direct supervision and control. In no event shall LES be liable for loss or damage caused by delay in labor beginning work when EXHIBITOR requests labor to begin later than the start of the working day. LES shall not be responsible for loss, delay or damage due to strike, lockouts, and/or work stoppages, or other causes beyond LES's reasonable control.

INDEMNIFICATION

LES agrees to indemnify, hold harmless, and defend EXHIBITOR from and against any and all demands, claims, causes of action, fines, penalties, damages, liabilities, judgments, and expenses (including but not limited to reasonable attorneys' fees and investigation costs) for bodily injury, including any injury to LES employees, or property damage arising out of work performed by labor provided by and supervised by LES, except when EXHIBITOR exercises direction and/or control over the work being performed.

LABOR PROVIDED UNDER THE SUPERVISION OF EXHIBITOR

RESPONSIBILITIES

EXHIBITOR shall be responsible for the performance of labor provided under this section. It is responsibility of EXHIBITOR to supervise labor secured through LES in a reasonable manner as to prevent bodily injury and/or property damage and also to direct them to work in a manner that is in compliance with LES Safe Work Rules and/or Federal, State, County and Local ordinances, rules and/or regulations, including but not limited to Show or Facility Management Rules and/or Regulations. It is the responsibility of EXHIBITOR to check in with the Service Desk to pick up labor, and to return to the Service Desk to release labor when the work is completed.

INDEMNIFICATION

EXHIBITOR agrees to indemnify, hold harmless, and defend LES from and against any and all demands, claims, causes of action, fines, penalties, damages, liabilities, judgements, and expenses (including but not limited to reasonable attorneys' fees and investigation costs) for bodily injury, including any injury to LES employees, and/or property damage arising out of work performed by labor provided by LES but supervised by EXHIBITOR. Further, EXHIBITOR's indemnification of LES includes any and all violations of Federal, State, County or Local ordinances, "Show Regulations and/or Rules" as published and/or set forth by Facility or Show Management, and/or directing labor provided by LES to work in a manner that violates any of the above rules, regulations, and/or ordinances.

IMPORTANT

PLEASE REFER TO LES's MATERIAL HANDLING TERMS AND CONDITIONS AS THEY RELATE TO MATERIAL HANDLING SERVICES. CONTRACTUAL TERMS DEPEND ON THE NATURE OF SERVICES SECURED BY EXHIBITOR THROUGH LES. TERMS & CONDITIONS MAY VARY FOR EACH TYPE OF SERVICE ORDERED THROUGH LES.

TERMS & CONDITIONS



SOLO RATE

ONE RATE. ONE FEE.

LEVY
EXPOSITION SERVICES INC.



THE SIMPLIFIED PRICING OF PAYING PER POUND INCLUDES:

- Receiving and unloading your materials at the advance warehouse.
- Secure storage of materials for up to 30 days before the show.
- Transfer to show-site, unload, and deliver materials to your booth.
- Removal and storage of empty containers during the show.
- Returning empties from storage at the close of the show.
- Outbound loading of your materials onto your carrier of choice or Levy's official carrier.



MATERIAL HANDLING FAQs

The following is a list of frequently asked questions pertaining to material handling and freight services. We strongly recommend that you read this document in its entirety to better familiarize yourself with the processes relating to material handling and freight services.

As the official service contractor, LEVY is the exclusive provider of freight services. Material handling includes unloading your exhibit material, storing up to 30 days in advance at the warehouse address, delivering to the booth, the handling of empty containers to and from storage, and removing of material from the booth for reloading onto outbound carriers. It should not be confused with the cost to transport your exhibit material to and from the convention or event. You have two options for shipping your advance freight — either to the warehouse or directly to show site.

HOW DO I SHIP TO THE ADVANCE WAREHOUSE?

- We will accept freight beginning 30 days prior to show move-in.
- To check on your freight arrival, call Exhibitor Services at the number listed on the Quick Facts.
- To ensure timely arrival of your materials at show site, freight should arrive by the deadline date listed on the Quick Facts and Shipping Instructions pages. Your freight will still be received after the deadline date, but additional charges will be incurred.
- The warehouse will receive shipments Monday through Friday, except holidays. Refer to the Shipping Instructions page for warehouse receiving hours.
- The warehouse will accept crates, cartons, skids, trunks/cases and carpets. Loose or pad-wrapped materials must be sent directly to show site.
- All shipments must have a bill of lading or delivery slip indicating the number of pieces, type of merchandise and weight.
- Certified weight tickets must accompany all shipments.
- Warehouse freight will be delivered to the booth prior to exhibitor setup.
- Please call the number located on the Quick Facts if you want to ship oversized material that requires special equipment to the warehouse.

HOW DO I SHIP TO SHOW SITE?

- Freight will be accepted only during exhibitor move-in. Please refer to the Quick Facts for the specific exhibitor move-in dates and times.
- All shipments must have a bill of lading or delivery slip indicating the number of pieces, type of merchandise and weight.
- Certified weight tickets must accompany all shipments.

WHAT ABOUT PREPAID OR COLLECT SHIPPING CHARGES?

- Collect shipments will be returned to the delivery carrier.
- To ensure that your freight does not arrive “collect,” mark your bill of lading “prepaid.”
- “Prepaid” designates that the transportation charges will be paid by the exhibitor or a third party.

HOW SHOULD I LABEL MY FREIGHT?

- The label should contain the exhibiting company name, the booth number and the name of the event.
- The specific shipping address for either the warehouse or show site can be found on the Quick Facts and Shipping Instructions pages.

HOW DO I ESTIMATE MY MATERIAL HANDLING CHARGES?

- Charges will be based on the weight of your shipment. Each shipment received is considered separately. The shipment weight will be multiplied by the applicable per pound rate with no round-ups. All shipments are subject to reweigh.
- On the Order Form, select whether the freight will arrive at the warehouse or be sent directly to show site.

Crated: material that is skidded or is in any type of shipping container that can be unloaded at the dock with no additional handling required.

- Add the late delivery charge listed on the Order Form if the shipment is accepted at the warehouse or at show site after the deadline date listed on the Quick Facts and Shipping Instructions pages.
- The above services, whether used completely or in part, are offered as a package and the charges will be based on the total inbound weight of the shipment.
- Shipments received without receipts or freight bills, such as UPS and Federal Express, will be delivered to the booth without guarantee of piece count or condition.

WHAT HAPPENS TO MY EMPTY CONTAINERS DURING THE SHOW?

- Pick up “Empty Labels” at the Service Center. Place a label on each container. Labeled containers will be picked up periodically and stored in non-accessible storage during the show.
- At the close of the show, the empty containers will be returned to the booth in random order. Depending on the size of the show, this process may take several hours.
- *Please note that LEVY will assume no liability for interrupted travel plans due to the length of time required for the empty container return. It is the responsibility of the exhibitor to schedule travel plans accordingly.*

HOW DO I PROTECT MY MATERIALS AFTER THEY ARE DELIVERED TO THE SHOW OR BEFORE THEY ARE PICKED UP AFTER THE SHOW?

- Consistent with trade show industry practices, there may be a lapse of time between the delivery of your shipment(s) to your booth and your arrival. The same is true for the outbound phase of the show — the time between your departure and the actual pick-up of your materials. During these times, your materials will be left unattended. We recommend that you arrange for a representative to stay with your materials or that you hire security services to safeguard your materials.

HOW DO I SHIP MY MATERIALS AFTER THE CLOSE OF THE SHOW?

- Each shipment must have a completed Material Handling Agreement in order to ship materials from the show. All pieces must be labeled individually.
- To save time, complete and submit the Outbound Shipping Form in advance, or you may contact the Service Center at show site for your shipping documents. The Material Handling Agreement and labels will be processed and available prior to show closing.
- After materials are packed, labeled, and ready to be shipped, the completed Material Handling Agreement must be turned in at the Service Center.
- Call your designated carrier with pick-up information. Please refer to the Quick Facts and Shipping Instructions pages for specific dates and times. In the event your selected carrier fails to show on final move-out day, your shipment will either be rerouted to LEVY’s carrier choice or delivered back to the warehouse at exhibitor’s expense.
- For your convenience, show-recommended carriers will be on site to handle outbound transportation.

WHERE DO I GET A FORKLIFT?

- Forklift orders to install or dismantle your booth after materials are delivered may be ordered in advance or at show site. We recommend that you order in advance to avoid additional charges at show site. Refer to the Order Form for available equipment.
- Advance and show-site orders for equipment and labor will be dispatched once a company representative signs the labor order at the Service Center.
- Start time is guaranteed only when equipment is requested for the start of the working day.

DO I NEED INSURANCE?

- Be sure your materials are insured from the time they leave your firm until they are returned after the show. It is suggested that exhibitors arrange all-risk coverage. This can be done by riders to your existing policies.
- All materials handled by LEVY are subject to the enclosed Terms and Conditions.

OTHER AVAILABLE SERVICES (may not be available in all locations)

- Cranes
- Scissor lifts, condors
- Access storage at show site
- Exhibit transportation services (see enclosed Liberty Convention Freight form)
- Security storage at show site
- Short-term and long-term warehouse storage
- Local pick-up and delivery



Fax: 253 437 0032
 14900 Interurban Avenue South, Suite 271
 Seattle, WA
 USA 98168
 Telephone: 253 437 0031
 E-mail: operations@levyexpo.com

**50th Annual Regional Anesthesiology and
 Acute Pain Medicine Meeting**
 May 1 - 3, 2025
 Rosen Shingle Creek
 Orlando, FL

SOLO RATE MATERIAL HANDLING ORDER FORM & INVOICE

SOLO RATE MATERIAL HANDLING SERVICES

DUE TO LIMITED MATERIAL HANDLING SERVICES AT THE ROSEN SHINGLE CREEK, WE HIGHLY RECOMMEND THAT ALL MATERIALS BE SHIPPED TO OUR ADVANCE WAREHOUSE IN ORDER TO AVOID POTENTIAL DELAYS IN UNLOADING AT SHOW SITE.

Material Handling Service:

Levy Exposition Services Inc. is the exclusive provider of Solo Rate Material Handling Services for 50th Annual Regional Anesthesiology and Acute Pain Medicine Meeting. Solo Rate Material Handling Services include:

- receiving and unloading your exhibit materials at the advance warehouse
- storage of exhibit materials for up to 30 days prior to the show
- transportation to show site, unloading and delivery of exhibit materials to your booth space,
- removal and storage of your empty containers during the event
- return of your empty containers at the close of the event
- outbound loading of your materials onto your carrier vehicle of choice at show site

You have the choice to ship to the advance warehouse prior to the show or to ship directly to the show site where your materials must arrive within the exhibitor move-in dates and times.

SOLO RATE MATERIAL HANDLING DESCRIPTIONS

Normal Warehouse Hours for Receiving Freight: 8:00 A.M. to 3:00 P.M. Monday through Friday, Holidays excluded.

Advance Receiving: Shipment(s) received at the Advance Warehouse *between* **March 26, 2025** and **April 23, 2025**.

Early/Late to Warehouse & Off Target: Shipment(s) received at the Advance Warehouse *prior too* **March 26, 2025** or *after* **April 23, 2025**. Shipments received at show site prior to **8:00 am** on **Wednesday, April 30, 2025**.

Show Site Receiving: Shipment(s) shipped to and received at the **Rosen Shingle Creek**. Shipments cannot be received at the **Rosen Shingle Creek** prior to **8:00 am** on **Wednesday, April 30, 2025**.

Dedicated Delivery from Advance Warehouse: Any freight received at the Advance Warehouse after **April 23, 2025** could incur a \$650.00 delivery fee if a dedicated truck is required to deliver freight to show site.

Advance and Direct Shipment Rates	Price Per lb.
Advance Warehouse Receiving Rate.....	\$3.15
Show Site Receiving Rate.....	\$2.95
Early/Late to Warehouse & Off Target Rate.....	\$3.40
Dedicated Delivery from Advance Warehouse (in addition to material handling rates).....	\$650.00 (flat fee)

PLEASE NOTE:

Acceptance of Terms & Conditions will be construed when the Material Handling Service Agreement is signed; or when exhibitor's materials are delivered to Levy Exposition Services Inc. warehouse or to a SHOW / EXPOSITION SITE for which Levy Exposition Services Inc. is the official show contractor.

Description	Weight in LBS	Price Per lb.	Estimated Total Charges
Advance Receiving - 1 crate, 2 boxes	298	\$3.15	\$938.70

EXHIBITOR INFORMATION

COMPANY _____

CONTACT _____ **BOOTH#** _____

RATE ADJUSTMENT (OFFICE USE ONLY)		
SUBTOTAL		
TOTAL	US DOLLARS	

PLEASE REFER TO THE PAYMENT & CREDIT CARD CHARGE AUTHORIZATION FORM
 ORDERS WILL NOT BE PROCESSED WITHOUT PAYMENT

SHIPPING INSTRUCTIONS

SHIPMENTS CAN BE SENT DIRECTLY TO THE SHOW-SITE ON MOVE-IN DAY, OR TO THE ADVANCE WAREHOUSE UP TO THIRTY DAYS PRIOR TO MOVE-IN.

All freight shipped to the advance receiving warehouse must be properly crated, boxed, or stretch wrapped on pallets.

ADVANCE RECEIVING

For advance receiving, mail or fax the Material Handling Order Form & Invoice with pre-payment to LEVY EXPOSITION SERVICES INC. Shipments sent collect **WILL NOT** be accepted.

Advance receiving includes the following:

- receiving your material at the warehouse up to thirty days in advance of the move-in day
- delivering the shipment to your booth at the facility
- removing empty crates from your booth to a designated storage area
- returning your empty crates to your booth at the close of the show
- loading your crates onto your designated carrier at the close of the show

The material handling services provided by LEVY EXPOSITION SERVICES INC. end with the close of the show. It is the responsibility of the exhibitor to make appropriate arrangements with a carrier for shipping following the close of the show. Please make special note of the allotted move-out times and days, and confirm with your carrier that they are able to meet these allotted times.

Please remove all old shipping labels and ensure that all freight destined for the advance warehouse is labeled with the following information:

**50th ASRA RA
COMPANY NAME & BOOTH #
Levy Exposition Services Inc.
c/o LibertyCFS
3732 Bryn Mawr St
Orlando, FL 32808**

Shipments may be sent to the advance warehouse up to thirty days prior to the move-in day for the show. All shipments however, must be received at the warehouse a minimum of one week (seven days) in advance of the show move-in date. Shipments received less than seven days prior to the move-in day are subject to extra charges and delivery time **will not** be guaranteed. All shipments must be received at the advance warehouse between the hours of 08:00 and 15:00, Monday to Friday, no earlier than **March 26, 2025** and no later than **April 23, 2025**. **Shipments that arrive prior to March 26, 2025 or after April 23, 2025 will be subject to the rate of \$3.40 per pound.**

ANY SHIPMENT(S) RECEIVED AT THE ADVANCE WAREHOUSE AFTER APRIL 23, 2025 WILL INCUR A CHARGE OF \$650.00 IF A DESIGNATED TRUCK IS REQUIRED TO DELIVER TO THE SHOW SITE.

Shipments must include an official weight ticket or bill of lading.

SHIPPING INSTRUCTIONS (CONT'D.)

SHOW-SITE RECEIVING

For show-site receiving, mail or fax the Material Handling Order Form & Invoice with pre-payment to LEVY EXPOSITION SERVICES INC. Shipments sent collect **WILL NOT** be accepted.

Show-site receiving includes the following:

- receiving and signing for your shipment on your behalf
- delivering the shipment to your booth at the facility
- removing empty crates from your booth to a designated storage area
- returning your empty crates to your booth at the close of the show
- loading your crates onto your designated carrier at the close of the show

The material handling services provided by LEVY EXPOSITION SERVICES INC. end with the close of the show. It is the responsibility of the exhibitor to make appropriate arrangements with a carrier for shipping following the close of the show. Please make special note of the allotted move-out times and days, and confirm with your carrier that they are able to meet these allotted times.

Please remove all old shipping labels and ensure that all freight destined for show-site receiving is labeled with the following information:

50th ASRA RA
COMPANY NAME & BOOTH #
Rosen Shingle Creek
c/o Levy Exposition Services Inc.
9939 Universal Blvd
Orlando, FL 32819

**PLEASE NOTE THAT SHIPMENTS CANNOT BE RECEIVED AT THE ROSEN SHINGLE CREEK
PRIOR TO 8:00 AM ON WEDNESDAY, APRIL 30, 2025.**

**ALL SHIPMENTS MUST INCLUDE A CERTIFIED WEIGHT TICKET OR BILL OF LADING. IN THE EVENT
THAT YOUR SHIPMENT(S) DOES NOT INCLUDE A CERTIFIED WEIGHT TICKET, IT WILL BE WEIGHED
ON-SITE AND A SURCHARGE OF \$0.25 PER POUND WILL BE APPLIED.**

LIMITS OF LIABILITY

See Material Handling Terms & Conditions Sheet enclosed.

MATERIAL HANDLING

Acceptance of said terms and conditions will be constructed when any of the following conditions are met:

- ~ **THE MATERIAL HANDLING ORDER FORM AND INVOICE IS SIGNED; OR**
- ~ **WHEN EXHIBITOR'S MATERIALS ARE DELIVERED TO LES'S WAREHOUSE OR TO A SHOW/ EXPOSITION SITE FOR WHICH LEVY EXPOSITION SERVICES INC. IS THE OFFICIAL SHOW CONTRACTOR; OR**
- ~ **WHEN AN ORDER FOR LABOR AND/ OR RENTAL EQUIPMENT IS PLACED BY AN EXHIBITOR WITH LEVY EXPOSITION SERVICES INC.**

1. **DEFINITIONS.** "Levy Exposition Services Inc" ("LES"), and any sub-contractors affiliated within the show.
2. **PACKAGING AND CRATES.** LES shall not be responsible for damage to loose, uncrated materials, pad-wrapped or shrink-wrapped materials, glass breakage, concealed damage, carpets in bags or poly, or materials improperly packed. In addition, LES shall not be responsible for crates and packaging which are unsuitable for handling, in poor condition, or have prior damage. Crated and packaging should be of a design to adequately protect contents for handling by forklift and similar means.
3. **EMPTY CONTAINERS.** Empty container labels will be available at the show site service desk. Affixing labels to the containers is the sole responsibility of EXHIBITOR or his representative. All previous labels must be removed or obliterated. LES assumes no responsibility for: Error in the above procedures; Removal of containers with old empty labels & without LES labels; or Improper information on empty labels. LES WILL NOT BE LIABLE FOR LOSS OR DAMAGE TO CRATES AND CONTAINERS OR THEIR CONTENTS WHEN SAID ITEMS ARE IN EMPTY CONTAINER STORAGE.
4. **INBOUND SHIPMENT(S).** Consistent with trade show industry practices, there may be a lapse of time between the delivery of shipment(s) to the booth and the arrival of EXHIBITOR or his representative, and during such time the materials will be left unattended. LES WILL NOT BE RESPONSIBLE OR LIABLE FOR ANY LOSS, DAMAGE, THEFT, OR DISAPPEARANCE OF EXHIBITOR'S MATERIALS AFTER SAME HAVE BEEN DELIVERED TO EXHIBITOR'S BOOTH AT SHOW SITE. LES highly recommends the securing of security services for Facility or Show Management.
5. **OUTBOUND SHIPMENT(S).** Consistent with trade show industry practices, there may be a lapse of time between the completions of packing and the actual pickup of materials from the booths for loading onto a carrier and during such time the materials will be left unattended. LES WILL NOT BE RESPONSIBLE OR LIABLE FOR ANY LOSS, DAMAGE, THEFT, OR DISAPPEARANCE OF EXHIBITOR'S MATERIALS BEFORE SAME HAVE BEEN PICKED UP FOR RELOADING AT THE CONCLUSION OF THE EVENT. LES highly recommends the securing of security services from Facility or Show Management. All Material Handling Agreements submitted to LES by EXHIBITOR will be checked at the time of pickup from booth and corrections will be made where discrepancies exist between the quantities of times listed by EXHIBITOR and the actual count of such items in the booth at the time of pickup.
6. **LES'S RESPONSIBILITIES.** LES shall be responsible only for those services which it directly provides. LES assumes no responsibility for any persons, parties, or other contracting firms not under LES's direct supervision and control. LES shall not be responsible for loss, delay, or damage due to strike, lockouts, work stoppages, natural elements, vandalism, acts of God, civil disturbances, power failure, explosion, acts of terrorism or war, other causes beyond LES's reasonable control, nor for ordinary wear & tear in the handling of materials.
7. **INSURANCE.** It is understood that LES is not an insurer. Insurance on exhibit materials, if any, shall be obtained by EXHIBITOR in amounts and for perils determined by EXHIBITOR. EXHIBITOR agrees to provide LES with a release of subrogation to the extent of any insurance settlement received.
8. **CLAIM(S) FOR LOSS.** Claims for loss or damage must be reported at show-site.
 - A. **PAYMENT FOR SERVICES MAY NOT BE WITHHELD.** In the event of any dispute between the EXHIBITOR shall not be entitled to and shall not withhold payment, or any partial payment due to LES for its services, as an offset against the amount of any alleged loss or damage.
 - B. **MAXIMUM RECOVERY.** If found damaged LES's sole and exclusive MAXIMUM liability for loss or damage to EXHIBITOR's materials and EXHIBITOR's sole and exclusive remedy is limited to \$.50 per pound article with a maximum liability of \$100.00 per item, or \$1,500.00 per shipment.
9. **JURISDICTION.** THIS CONTRACT SHALL BE CONSTRUED UNDER THE LAWS OF THE STATE OF FLORIDA WITHOUT GIVING EFFECT TO ITS CONFLICT OF LAWS RULES. EXCLUSIVE VENUE FOR ALL DISPUTES ARISING OUT OF OUR RELATING TO THIS CONTRACT SHALL RESIDE IN A COURT OF COMPETENT JURISDICTION IN ORLANDO, FLORIDA.
10. **INDEMNIFICATION.** EXHIBITOR agrees to indemnify, forever hold harmless and defend LES, its employees, directors, officers, and agents from and against any and all demands, claims, causes of action, fines, penalties, damages (including consequential), liability, judgments, and expenses (including but not limited to reasonable attorney's fees and investigation costs) on account of personal injury, death, or damage to or loss of property or profits arising out of, or contributed to, by any of the following:
 - EXHIBITOR's negligent supervision of any labor secured through LES, or the negligent supervision of such labor by any of EXHIBITOR's employees, agents, representative, customers, invitees and/or Exhibitor Appointed Contractor (EAC).
 - EXHIBITOR's negligence, willful misconduct, or deliberate act of EXHIBITOR's employees, agents, representatives, customers, invitees and/or any Exhibitor Appointed Contractor (EAC) at the show or exposition to which this contract relates.
 - EXHIBITOR's violation of U.S.A. or Local ordinances or the violation of Show Regulations and/or Rules as published and set forth by Facility and/or Show Management.
 - EXHIBITOR's inclusion of illegal substances, hazardous materials or waste in any shipment placed with LES and for the violation of the representations and warranties made regarding hazardous materials made on the front of this Agreement.
11. **MISCELLANEOUS.** EXHIBITOR, as a material part of the consideration LES for material handling and transportation services, waives and releases all claims against LES, its employees, agents, officers, and directors, with respect to all matters for which LES has disclaimed liability pursuant to the provisions of this contract. The EXHIBITOR acknowledges that he or she has read this agreement, understands it and agrees to be bound by its terms, and further agrees that it is the complete and exclusive agreement between the parties. The invalidity or enforceability of any provision hereof shall not affect, modify, or impair the validity and enforceability of all provisions herein.



ADVANCE WAREHOUSE

TO: _____
(EXHIBITOR NAME)

BOOTH # _____

**Levy Exposition Services Inc.
c/o LIBERTY CFS NV, INC.
3732 Bryn Mawr St
Orlando, FL 32808**

EVENT NAME:

50th ASRA RA

NO. _____ # of _____ PCS.



ADVANCE WAREHOUSE

TO: _____
(EXHIBITOR NAME)

BOOTH # _____

**Levy Exposition Services Inc.
c/o LIBERTY CFS NV, INC.
3732 Bryn Mawr St
Orlando, FL 32808**

EVENT NAME:

50th ASRA RA

NO. _____ # of _____ PCS.

The above labels are provided for your convenience.
Place one on each piece shipped to the ADVANCE WAREHOUSE.
If more labels are needed, copies are acceptable.



SHOW SITE

TO: _____
(EXHIBITOR NAME)

BOOTH # _____

**Rosen Shingle Creek
c/o Levy Exposition Services Inc.
9939 Universal Blvd
Orlando, FL 32819**

EVENT NAME:

50th ASRA RA

NO. _____ # of _____ PCS.



SHOW SITE

TO: _____
(EXHIBITOR NAME)

BOOTH # _____

**Rosen Shingle Creek
c/o Levy Exposition Services Inc.
9939 Universal Blvd
Orlando, FL 32819**

EVENT NAME:

50th ASRA RA

NO. _____ # of _____ PCS.

The above labels are provided for your convenience.
Place one on each piece shipped to the SHOW SITE.
If more labels are needed, copies are acceptable.



"Delivering Freedom®"



MOVE YOUR EXHIBIT WITH PEACE OF MIND

**THE FREIGHT & CUSTOMS PARTNER YOU CAN RELY ON
FULLY DEDICATED TO YOUR CONVENTION AND TRADE SHOW SUCCESS**

Putting service first and leveraging our 42 years of freight & customs experience



Transportation Services

- Ground Freight (LTL)
- Full Load
- International Freight Forwarding
- Customs Brokerage Services
- Exclusive Use Full Trailer



Customized Solutions

- Door to door service
- Catering to your specific needs
- Single point of contact
- 24/7 customer attention
- Committed to excellence

Dedicated to delivering safely and on time every time.



**Call Toll Free 1-866-938-1092 or 1.905.338.3993
email: exhibitorservices@libertycfs.us - www.libertycfs.us**

LAS VEGAS | TORONTO





LibertyCFS NV, Inc.

A Veteran Owned Company
Delivering Freedom

exhibitorservices@libertycfs.us

www.libertycfs.us

Tel. (905) 338-3993

FREIGHT & CUSTOMS ORDER FORM

1 Please accept this form as authority for LibertyCFS NV, Inc. to provide the services listed below. A second form is required for additional events.

Adobe Acrobat Reader DC may be required for completion of form. Click image to download 

Freight Only
 Customs Only
 Freight & Customs
 Return Only

2a PICK-UP LOCATION

Company Name _____
 Address1 _____
 Address2 _____
 City _____ State _____ ZipCode _____
 Contact _____ Phone # _____
 Email _____ IRS/Tax ID# _____

3 DELIVERY TO ADDRESS

Exhibiting Company Name _____ Booth # _____
 Show Name _____
 Address1 _____
 Address2 _____
 City _____ State _____ ZipCode _____
 Onsite Contact _____ Cell Phone # _____

2b SERVICES

P/U Date _____ From _____ To _____ Hours _____
 DlvY Date _____ Hours _____

Express
 Economy LTL 7-10 Days
 Int'l
 Inside
 Liftgate
 Dock
 Other _____

4 RETURN TO

Check Box if the Return address is the same as 2a

Consignee: _____
 Address1 _____
 Address2 _____
 City _____ State _____ ZipCode _____
 Contact _____ Phone # _____
 PU Date _____ Arrive by _____

5 PACKAGE INFO

Carton(s)/Box
 Vinyl Case(s)/Color
 Wooden Crate(s)
 Trunk(s) / On Wheels
 Skid(s) - to contain # _____ of pieces



PCS	DIMENSIONS (L x W x H)	WGT
TOTAL PIECES		TOTAL WEIGHT

6 VALUE

Declared Value for Carriage: The declared value for carriage of this shipment is agreed to and understood to be \$0.50 per pound multiplied by the number of pounds of that part of the shipment lost or damaged but not less than \$50.00 per shipment unless a value is declared below and applicable charges paid thereon. The liability of Carrier for loss/damage are subject to the terms and conditions. LibertyCFS NV, Inc charges 8% per \$1000, Min \$80.

Exclusion: Does not include TV(s)/Monitor(s) **DECLARED VALUE** _____

7 PAYMENT

Credit Card Information / Billing Address   

Credit Card Number _____ Security Code _____ Exp. Date ____ / ____
 I hereby authorize the use of this card for payment of services related to this Order Form. I understand that declined credit cards are subject to a 30% surcharge.

Address _____ Signature _____
 City _____ State _____ ZipCode _____
 Phone _____ Email _____

Comments: Include any additional comments that will be helpful for the movement of freight and contents

Print



Fax: 253 437 0032
 14900 Interurban Avenue South, Suite 271
 Seattle, WA
 USA 98168
 Telephone: 253 437 0031
 E-mail: operations@levyexpo.com

**50th Annual Regional Anesthesiology and
 Acute Pain Medicine Meeting**
 May 1 - 3, 2025
 Rosen Shingle Creek
 Orlando, FL

REQUEST FOR SET-UP BY NON-OFFICIAL CONTRACTOR

The unpacking, erection, assembling, dismantling, and packing of displays and equipment must be done by the correct type of labor. Levy Exposition Services Inc., the official contractor, will have skilled craftsmen available to assist Exhibitors. Arrangements for labor should be made through Levy Exposition Services in advance whenever possible. Official labor forms are included in the Exhibitor Service Manual.

Exceptions to the foregoing will be considered only in cases where permission has been requested in writing by the Exhibitor and **received by Levy Exposition Services Inc. no later than April 10, 2025.** Exceptions will be granted only if it will not interfere with or prejudice the orderly set-up, interim service, or dismantling of the Exposition. An exception will not be granted if it is inconsistent with the commitments made and obligations assumed by Management in any contract with service contractors or its lease with the **Rosen Shingle Creek.** For services such as electrical, plumbing, telephone, drayage, rigging and booth cleaning, no exception will be made, and the contractor designated by Management will be used.

All agents representing the Exhibitor must be fully identified by the official Management badge. All agents or representatives who are performing services other than the Exhibitor's own employees must provide Levy Exposition Services with **Certificates of Insurance naming Levy Exposition Services Inc., ASRA Pain Medicine, 50th Annual Regional Anesthesiology and Acute Pain Medicine Meeting, and the Rosen Shingle Creek as additional insured's by April 10, 2025.** These Certificates of Insurance must include public liability and property damage insurance for at least \$1,000,000, and workmen's compensation insurance in accordance with local law.

Exhibitors wishing to use a contractor other than Levy Exposition Services Inc. to set up and dismantle their exhibits must fill out this form and return to us no later than April 10, 2025. If this form and the certificate of insurance from the non-official contractor is not received by April 10, 2025, your non-official contractor will be allowed to supervise only. All labor must then be hired from Levy Exposition Services Inc. for installation and dismantle of the exhibit.

**ORIGINAL CERTIFICATES ONLY
 PHOTOSTATS OR FACSIMILES WILL NOT BE ACCEPTED**

Name of Exhibiting Company: _____ Booth Number: _____

Contracting Company Name: _____

Contracting Company Address: _____

City: _____ State: _____ Zip: _____ Telephone: _____ Fax _____

Estimated Arrival at Show _____ Number of Workers: _____

Authorized By: _____ Title: _____
 (Sign & Print Name)

ACCESSIBLE STORAGE INFORMATION

Accessible storage will be available to you at this show. You must sign up for the service at the Levy Exposition Services Inc. desk and pick up your accessible storage labels. All freight received at the show will be delivered to your booth space first, and when properly labeled will be placed in accessible storage.

This is not an order form. This service must be ordered on site.

Accessible Storage is **NOT** Secured Storage.

NOTE: Accessible Storage items are not necessarily the first items returned to your booth at the close of the show.

Rates are for SET UP, STORAGE SPACE PER DAY, AND EACH TIME ACCESSED, and are as follows:

SET UP:

One time set up charge of \$100.00

STORAGE RATES:

(RATES ARE PER SQUARE FOOT INCREMENTS OR PORTION THEREOF PER DAY.)

0 - 25	square feet	\$150.00
26 - 50	square feet	\$200.00
51 - 100	square feet	\$250.00
101 - 150	square feet	\$300.00
151 - 200	square feet	\$350.00

ACCESS RATES:

There is a 1/2 hour labor charge (minimum) each time items are placed into or removed from accessible storage. This charge will be applied at the corresponding rate for the time it is accessed.

LABOR RATES:

STRAIGHT TIME	8:00 AM - 4:30 PM Monday to Friday	\$155.00 per Hour
OVER TIME	4:30 PM - 8:00 AM Monday to Friday, All day Saturday and Sunday	\$235.00 per Hour



CUSTOM FURNITURE

PRODUCT

CATALOG

Special Events | Trade Shows | Corporate Functions



253-437-0031

www.levyexpo.com

Specialty Furniture Rental 





FULTON Sofa
Black Leather
80"L x 31"D x 32"H
120 lbs



FULTON Love Seat
Black Leather
57"L x 31"D x 32"H
88 lbs



FULTON Chair
Black Leather
33"L x 31"D x 32"H
54 lbs



VERONA SOFA
WHITE Leather
78"L x 28.75"D x 28.25"H
128 lbs



VERONA LOVE SEAT
White Leather
57"L x 28.75"D x 28.25"H
100 lbs



VERONA Chair
White Leather
27"L x 35"D x 28.75"H
68 lbs

Lounge



DEIRA Curved Sofa
White Leather
82"L x 34"D x 31"H



DEIRA Reversed Curved Love Seat
White Leather
72"L x 34"D x 31"H



DEIRA Curved Bench
White Leather
70"L x 26"D x 19"H



DEIRA Round Ottoman
White Leather
39" Dia x 17"H



DEIRA RECTANGLE OTTOMAN
White Leather
60"L x 27"D x 19"H



ETERNITY Mod Lounge



ETERNITY Mod Chair
White Leather
28"L x 28"D x 36"H



ETERNITY Mod Wedge
White Leather
26"L x 28"D x 17"H

Lounge

LEVY

EXPOSITION SERVICES INC.



AVENDALE Sofa
Beige Upholstery
90"L X 34.5"D X 34"H



AVENDALE Love Seat
Beige Upholstery
78"L X 34.5"D X 34"H



AVENDALE Chair
Beige Upholstery
40"L X 34.5"D X 34"H



BRISBANE Sofa | Grey Upholstered
65"L X 30"D X 31"H



BRISBANE Chair | Grey Upholstered
30"L X 30"D X 32"H

Lounge



**KENWOOD Love Seat | Light Beige
Linen Upholstery**
63"L X 29"D X 34"H



**KENWOOD Chair | Light Beige
Linen Upholstery**
27"L X 27"D X 34"H



**NAPLES Sofa
Yellow Upholstery**
70"L X 29"D X 32"H



**NAPLES Love Seat
Yellow Upholstery**
50"L X 29"D X 32"H



**NAPLES Chair
Yellow Upholstery**
31"L X 29"D X 32"H



Lounge



**LAGUNA Armless Chair
White Cushion**
28"L x 35"D x 29"H, 34 lbs



**LAGUNA Ottoman
White Cushion**
28"L x 28"D x 19"H, 19 lbs



**LAGUNA Corner Chair
White Cushion**
35"L x 35"D x 29"H, 79 lbs



CYPRESS Cocktail Table
35.5"L x 35.5"D x 18.5"H, 45 lbs



LAGUNA Tree Stump End Table
18"L x 15"D x 16.5"H, 19 lbs



**LAGUNA Armless Chair
Wheat Cushion**
28"L x 35"D x 29"H, 34 lbs



**LAGUNA Ottoman
Wheat Cushion**
28"L x 28"D x 19"H, 19 lbs



**LAGUNA Corner Chair
Wheat Cushion**
35"L x 35"D x 29"H, 79 lbs



Outdoor Lounge



MADISON Cocktail Table
White Marble
44"L x 20"D x 18"H, 20 lbs



MADISON End Table
White Marble
24"L x 20"D x 22"H, 10 lbs



MADISON Cocktail Table
Black Marble
44"L x 20"D x 18"H, 20 lbs



MADISON End Table
White Marble
24"L x 20"D x 22"H, 10 lbs



SYDNEY Cocktail Table
Glass / Chrome
47"L x 23"D x 17"H, 26 lbs



SYDNEY End Table
Glass / Chrome
20"L x 20"D x 19"H, 21 lbs



ALTON Cocktail Table | White / Chrome
****Charged**
44"L x 22"D x 15"H, 25 lbs



WINDSOR Side Table
Yellow
17"L x 17"D x 24"H, 12 lbs



WHITNEY End Table | Gold
22"L x 22"D x 28.8"H, 15 lbs



CLASSIC Side Table
White / Chrome
18"L x 16"D x 25"H, 10 lbs

Cocktails / Ends Tables



CATO Cube Ottoman
White Leather
17.5"L x 17.5"D x 16.5"H



CATO Cube Ottoman
Black Leather
17.5"L x 17.5"D x 16.5"H



White Swivel Ottoman
White Leather
18"L x 18"D x 18"H



DEIRA Curved Bench
White Leather
70"L x 26"D x 19"H



DEIRA RECTANGLE OTTOMAN
White Leather
60"L x 27"D x 19"H



DEIRA Round Ottoman
White Leather
39"Dia x 17"H



Ottomans / Benches



NOVA Armless Chair | White / Chrome
18"L x 22"D x 36"H



NOVA Armless Chair | Black / Chrome
18"L x 22"D x 36"H



LLOYD Chair | White / Chrome
22"L x 19"D x 33"H



EAMES Chair | White - Wooden Legs
18"L x 17"D x 32"H



GUN METAL Chair | Gray
19"L x 18"D x 33"H



CONSTANTINE Stage Chair
White
30"L x 30"D x 38"H



TWILIGHT Stage Chair
Black
27.5"L x 25.5"D x 28"H



SIERRA Stage Chair
White
26"L x 23"D x 35"H

Occasional Chairs



31" Short Cafe Table | Glass / Chrome
31.5"Dia x 29"H, 48 lbs



30" Short Cafe Table | Black
30"Dia x 31"H, 39 lbs



30" Short Tulip Cafe Table | White
30"Dia x 30"H, 30 lbs



42" Short Tulip Cafe Table | White
42"Dia x 30"H, 47 lbs



31.5" EAMES Table
White / Wood Legs
31.5"Dia x 29"H, 21 lbs



36" X Base Glass Dining Table
Glass / Chrom
36" Dia x 30"H"



Short Cafe' / Glass Dining Tables



NEO Bar Stool | White | Black
17"L x 18"D x 37-45.25"H
Adjustable / Swivel



GIOVANNI Mid Back Bar Stool | White | Black
20"L x 18"D x 36.75-45.25"H
Adjustable / Swivel



DAWSON Curve Bar Stool | White
15"L x 15"D x 31-35"H, 35 lbs
Adjustable / Swivel



DAWSON Curve Bar Stool | Black
15"L x 15"D x 31-35"H, 35 lbs
Adjustable / Swivel



ASHTON Swivel Bar Stool | White
21"L x 21"D x 32-40"H
Adjustable / Swivel



ASHTON Swivel Bar Stool | Black
21"L x 21"D x 32-40"H
Adjustable / Swivel

Bar Stools



NOVA Bar Stool | White / Chrome
17"L x 20"D x 41"H



ELON Bar Stool | White / Chrome
17"L x 16"D x 43"H



GUN METAL Bar Stool | Gray
17"L x 17"D x 30"H, 10 lbs



GUN METAL Bar Stool | Gray
20.5"L x 20"D x 46"H, 15 lbs



HAYWARD Bar Stool
White / Natural
20"L x 18"D x 29.5"H



Bar Stools



23" Tall Bar Table
Glass / Chrome
23.75"Dia x 41.75"H, 27 lbs



24" Square Bar Table
White / Chrome
24" Sqr. x 33-41"H, 28 lbs

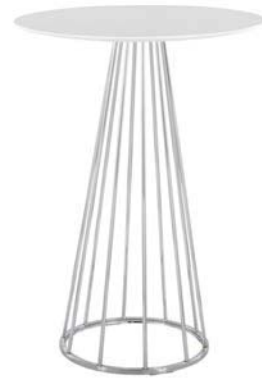

27" LENUX Table
White / Chrome
27"Dia x 42"H



27.5" Tall Bar Table
White / Chrome
27.5"Dia x 26-41"H, 24 lbs



27.5" Tall Bar Table
Black / Chrome
27.5"Dia x 26-41"H, 24 lbs



30" Tall Bar Table
Black / Black
30"Dia x 42"H, 47 lbs



23" Tall Bar Table
Black / Black Round Base
23"Dia x 40"H, 19 lbs

Tall Bar Tables



42" LOCKING Pedestal Cabinet | Black
24"L x 24"D x 42"H



42" LOCKING Pedestal Cabinet | White
24"L x 24"D x 42"H



5' MADISON Pub Table
White
60"L x 23"D x 42"H, 75 lbs



5' MADISON "CHARGED" Pub Table
White
60"L x 23"D x 42"H, 80 lbs



4.75' COMMUNAL Table | White
4.75'L x 23.75"D x 40"H, 108 lbs



5' LED GLOW Table
60"L x 24"D x 40"H, 90 lbs

Changes Color



Pedestals / Pub Tables



Reception Counter | White
47.75"L x 19.5"D x 42.75"H, 95 lbs



Reception Counter | Black
47.75"L x 19.5"D x 42.75"H, 95 lbs



6' VIP Straight Bar
White Acrylic / Polished Silver
72"L x 24"D x 42"H



6' DIAMOND Straight Bar
White Acrylic / Polished Silver Design
72"L x 30"D x 40"H *Shown Below



VENETIAN Back Bar | White Shelving
37"L x 7.8"D x 59"H



Bars & Reception Counters



COMMODORE EXECUTIVE CHAIR
Black / Chrome
Seat Adjust from 17" to 21"H



COMMODORE EXECUTIVE CHAIR
White / Chrome
Seat Adjust from 17" to 21"H



EXECUTIVE GUEST CHAIR | Black
27"L x 27"D x 40"H



TASK CHAIR w/ Arms | Black
Seat Adjust from 17" to 22"H



DRAFTING STOOL | Black
Seat Adjust from 22" to 32"H



ABERDEEN 8' Conference Table | Grey
96"L x 48"D x 29.5"H, 322 lbs

ABERDEEN 10' Conference Table | Grey
120"L x 48"D x 29.5"H, 322 lbs



DISTRICT 8' Conference Table | Grey
96"L x 47"D x 27.5"H, 138 lbs



Office



8' FOLIAGE Backdrop Wall
8'L x 24"D x 8'H



16' FOLIAGE Backdrop Wall
16'L x 24"D x 8'H

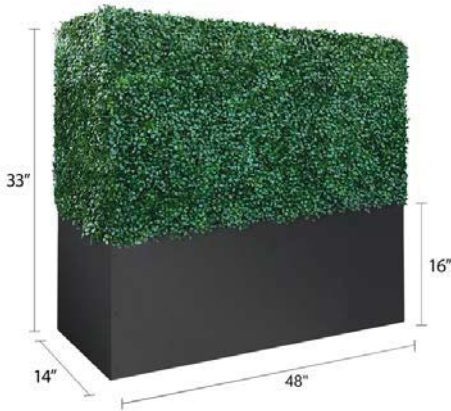

33''H Box Hedge Wall
48"L x 14"D x 33"H

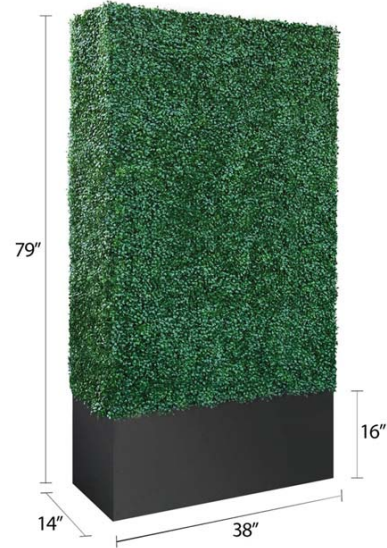

79''H Box Hedge Wall
38"L x 14"D x 79"H

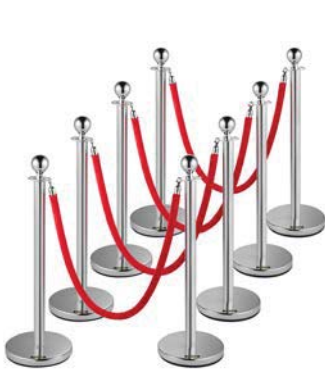

Stanchion Pole Chrome
12"L x 37"H



Stanchion Velvet Rope | Red
5' Velvet Rope
*Also Available in Black or Orange



Retractable Belt Stanchion | Black
40"H

Accessories



GLOW Cube | Adjustable Colors
20"L x 20"D x 20"H



Refrigerator
20"L x 20"D x 34"H
3.3 CuFt | 110 Volts / 155.25 Watts



Bag Rack | Chrome
45"H | 16" Straight Arm

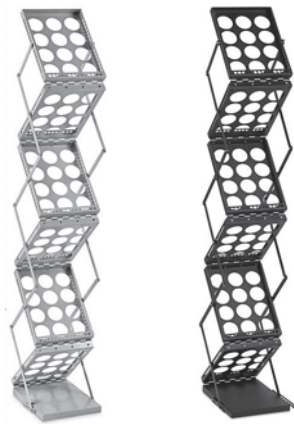

6 Pocket Literature Stand
Silver or Black
10.75"L x 14.25"D x 58"H



LIGHTED MARQUEE LETTERING
White Letters | Clear LED Bulbs
3 ft. Tall | Standard 110 electric required



Coat Rack | Black
12.6"W x 67"H



TURINO Floor Lamp
Chrome
10"L x 10"D x 67"H



Free Standing Mirror
24"L x 24.5" D x 64"H



Throw Pillows
Various Colors
13"L x 13"W

Accessories



LEVY
EXPOSITION SERVICES INC.
www.levyexpo.com



Email Orders to: operations@levyexpo.com
 Fax: 253 437 0032
 Phone: 253 437 0031



Company Information		Delivery Information	
Company Name:		Event:	
Address:		Location:	
Phone:		Booth #:	
E-Mail:		Delivery Date/Time:	
OnSite Contact:		Strike Date/Time:	
		Event Start Date/Time:	
		Event End Date/Time:	

*Orders received after 3 weeks prior to event are based on availability and subject to a 30% Late Fee.
 *25% cancellation will be applied to all orders received and canceled 3 weeks prior to install.
 *100% cancellation will be applied if canceled on day of delivery.
 *Check or Credit Card must accompany order. 100% of payment required prior to delivery.
 Items missing or returned damaged are subject to replacement charges.

ITEM NAME	DIMENSIONS	EVENT RATE	Qty.	Total
Lounge Sofas / Love Seats / Chairs				
VERONA White Leather Sofa	78"L x 28.75"D x 28.25"H	\$929.00		\$
VERONA White Leather Love Seat	57"L x 28.75"D x 28.25"H	\$838.00		\$
VERONA White Leather Chair	27"L x 35"D x 28.75"H	\$576.00		\$
FULTON Black Leather Sofa	80"L x 31"D x 32"H	\$929.00		\$
FULTON Black Leather Love Seat	57"L x 31"D x 32"H	\$838.00		\$
FULTON Black Leather Chair	33"L x 31"D x 32"H	\$576.00		\$
AVENDALE Upholstered Sofa / Beige	90"L x 34.5"D x 34"H	\$929.00		\$
AVENDALE Upholstered Love Seat / Beige	78"L x 34.5"D x 34"H	\$838.00		\$
AVENDALE Upholstered Chair / Beige	40"L x 34.5"D x 34"H	\$576.00		\$
BRISBANE Upholstered Sofa / Grey	65"L x 30"D x 31"H	\$929.00		\$
BRISBANE Upholstered Chair / Grey	30"L x 30"D x 32"H	\$576.00		\$
KENWOOD Upholstered Love Seat / Light Beige	63"L x 29"D x 34"H	\$838.00		\$
KENWOOD Upholstered Chair / Light Beige	27"L x 27"D x 34"H	\$576.00		\$
NAPLES Upholstered Sofa / Yellow	70.5"L x 29"D x 32"H	\$1086.00		\$
NAPLES Upholstered Love Seat / Yellow	50.8"L x 29"D x 32"H	\$996.00		\$
NAPLES Upholstered Chair / Yellow	31"L x 29"D x 32"H	\$663.00		\$
DEIRA Curved Sofa / White Leather	82"L x 34"D x 31"H	\$1014.00		\$
DEIRA Reversed Curved Love Seat / White Leather	72"L x 34"D x 31"H	\$984.00		\$
DEIRA Curved Bench / White Leather	70"L x 26"D x 19"H	\$617.00		\$
DEIRA Round Ottoman / White Leather	39"Dia x 17"H	\$470.00		\$
DEIRA Rectangle Ottoman / White Leather	60"L x 27"D x 19"H	\$470.00		\$
ETERNITY Mod Lounge Chair	28"L x 28"D x 36"H	\$473.00		\$
ETERNITY Mod Lounge Wedge	26"L x 28"D x 17"H	\$390.00		\$
LAGUNA OUTDOOR Armless / White	28"L x 35"D x 29"H	\$446.00		\$
LAGUNA OUTDOOR Corner / White	35"L x 35"D x 29"H	\$473.00		\$
LAGUNA OUTDOOR Ottoman / White	28"L x 28"D x 19"H	\$273.00		\$
LAGUNA OUTDOOR Armless / Wheat	28"L x 35"D x 29"H	\$446.00		\$
LAGUNA OUTDOOR Corner / Wheat	35"L x 35"D x 29"H	\$473.00		\$
LAGUNA OUTDOOR Ottoman / Wheat	28"L x 28"D x 19"H	\$273.00		\$
Cocktail / End Tables				
MADISON Cocktail Table / White	44"L x 20"D x 18"H	\$320.00		\$
MADISON Cocktail Table / Black	44"L x 20"D x 18"H	\$320.00		\$
MADISON End Table / White	24"L x 20"D x 22"H	\$314.00		\$
MADISON End Table / Black	24"L x 20"D x 22"H	\$314.00		\$
ALTON Cocktail Table / White (Charged)	44"L x 22"D x 15"H	\$482.00		\$
SYDNEY Glass Cocktail Table / Chrome	47"L x 23"D x 17"H	\$368.00		\$
SYDNEY Glass End Table / Chrome	20"L x 20"D x 19"H	\$314.00		\$
CYPRESS Cocktail Table	35.5"L x 35.5"D x 18.5"H	\$347.00		\$
LAGUNA Tree Stump End Table	18"L x 15"D x 16.5"H	\$326.00		\$
WHITNEY End Table - Gold	22"D x 22"W x 28.8"H	\$326.00		\$

WINDSOR End Table - Yellow	17"D x 17"W x 24"H	\$326.00		\$
CLASSIC End Table - White / Chrome	19.75"L x 11.75"D x 23.75"H	\$167.00		\$

Ottomans / Benches

CATO Cube Ottoman / White	17.5"L x 17.5"D x 16.5"H	\$173.00	\$
CATO Cube Ottoman / Black	17.5"L x 17.5"D x 16.5"H	\$173.00	\$
White Swivel Ottoman / White	18"L x 18"D x 18"H	\$173.00	\$
DEIRA Round Ottoman / White Leather	39"Dia x 17"H	\$470.00	\$
DEIRA Rectangle Ottoman / White Leather	60"L x 27"D x 19"H	\$470.00	\$
DEIRA Curved Bench / White Leather	70"L x 26"D x 19"H	\$617.00	\$

Occasional Chairs

NOVA Chair / White - Chrome	18"L x 22"D x 36"H	\$234.00	\$
NOVA Chair / Black - Chrome	18"L x 22"D x 36"H	\$234.00	\$
LLOYD Chair / White - Chrome	22"L X 19"W X 33"H	\$234.00	\$
EAMES Chair / White - Natural Wooden Legs	18"L x 17"D x 32"H	\$248.00	\$
Gun Metal Chair - Grey	19"L x 18"D x 33"H	\$234.00	\$
CONSTANTINE Stage Chair / White	30"L x 30"D x 38"H	\$558.00	\$
SIERRA Stage Chair / White	26"L x 23"D x 35"H	\$361.00	\$
TWILIGHT Stage Chair / Black	27.5"L x 25.5"D x 28"H	\$513.00	\$

Short Café / Dining Tables

30" Short Café Table - Black / Black Base	30" Dia x 31"H	\$258.00	\$
31" Short Glass Café Table / Chrome Base	31"Dia x 29"H	\$293.00	\$
30" Short Tulip Café Table - White	30" Dia x 30"H	\$318.00	\$
31.5" EAMES Table / White - Wooden Legs	31.5"Dia. x 29"H	\$293.00	\$
36" X Base Glass / Chrome Dining Table	36" Dia x 30"H	\$318.00	\$
42" Short Tulip Café Table - White	42" Dia x 30"H	\$381.00	\$

Tall Bar Tables

23" Glass Tall Bar Table	23.75"Dia. x 42"H	\$381.00	\$
23" Round Tall Bar Table - Black Round Base	23"Dia x 40"H	\$300.00	\$
24" Square Tall Bar Table / White - Chrome	23.75" Sqr. x 33-41"H (<i>Adjustable</i>)	\$360.00	\$
27.5" Round Tall Bar Table / Black - Chrome	27.5"Dia x 26"-41"H (<i>Adjustable</i>)	\$347.00	\$
30" Round Tall Bar Table / Black - Black Base	30"Dia x 42"H	\$336.00	\$

Bar Stools

ASHTON Swivel Stool / White - Chrome	15"L x 15"D x 24.5"-29.5"H (<i>Adjustable</i>)	\$264.00	\$
ASHTON Swivel Stool / Black - Chrome	15"L x 15"D x 24.5"-29.5"H (<i>Adjustable</i>)	\$264.00	\$
HAYWARD Bar Stool / Natural - White	20"L x 18"D x 29.5"H	\$264.00	\$
Black Arm Bar Stool	24"L x 22"D x 42"H	\$264.00	\$
DAWSON Curve Bar Stool / White - Chrome	15"L x 15"D x 31"-35"H (<i>Adjustable</i>)	\$264.00	\$
DAWSON Curve Bar Stool / Black - Chrome	15"L x 15"D x 31"-35"H (<i>Adjustable</i>)	\$264.00	\$
NOVA Bar Stool - White - Chrome	17"L x 20"D x 41"H	\$264.00	\$
ELON Bar Stool - White - Chrome	17"L x 16"D x 43"H	\$264.00	\$
NEO Bar Stool / White - Chrome - Armless	17"L x 18"D x 37"-45.25"H (<i>Adjustable</i>)	\$293.00	\$
NEO Bar Stool / Black - Chrome - Armless	17"L x 18"D x 37"-45.25"H (<i>Adjustable</i>)	\$293.00	\$
GIOVANNI Mid Back Bar Stool / White - Swivel	21"L x 21"D x 32.7"-40.6"H (<i>Adjustable</i>)	\$293.00	\$
GIOVANNI Mid Back Bar Stool / Black - Swivel	21"L x 21"D x 32.7"-40.6"H (<i>Adjustable</i>)	\$293.00	\$
Gun Metal Bar Stool / Grey - Armless - Backless	17"L x 17"D x 30"H	\$264.00	\$
Gun Metal Bar Stool / Grey - w/ Back	20.5"L x 20"D x 46"H	\$293.00	\$

Display Pedestals				
24" Locking Pedestal / White	24"L x 24"D x 42"H"	\$617.00		\$
24" Locking Pedestal / Black	24"L x 24"D x 42"H"	\$617.00		\$
Bars / Reception Counters / Pub Tables				
Reception Counter / White	47.75"L x 19.5D" x 42.75H"	\$537.00		\$
Reception Counter / Black	47.75"L x 19.5D" x 42.75H"	\$537.00		\$
4.75' Communal Table / White	57"L x 23.75"D x 40"H	\$732.00		\$
5' Madison Pub Table / White	60"L x 23"D x 42"H	\$819.00		\$
5' Madison Pub Table / White "Charged"	60"L x 23"D x 42"H	\$966.00		\$
5' LED GLOW Table	60"L x 24"D x 40"H	\$1433.00		\$
6' VIP Straight Bar - White Acrylic	72"L x 24"D x 42"H	\$1020.00		\$
6' DIAMOND Straight Bar - White Acrylic - Polished Silver Design	72"L x 30"D x 42"H	\$1178.00		\$
Office				
Black Leather Executive Chair / Black	Seat Adjust from 17" to 21"H	\$375.00		\$
COMMODORE Leather Executive Chair / BLACK - Chrome	Seat Adjust from 17" to 21"H	\$429.00		\$
COMMODORE Leather Executive Chair / WHITE - Chrome	Seat Adjust from 17" to 21"H	\$429.00		\$
Mid-Back Leather Executive Guest Chair / Black	27"L x 27"D x 40"H	\$375.00		\$
Task Chair with Arms / Black	Seat Adjust from 19" to 24"H	\$293.00		\$
Drafting Stool / Black	Seat Adjust from 25" to 30"H	\$336.00		\$
2 Drawer Letter Size Filing Cabinet / Black	26"L x 14"D x 22"H	\$293.00		\$
8' DISTRICT Executive Conference Table / Grey & Black	95.2"L x 47.2"D x 27.5"H	\$1011.00		\$
8' ABERDEEN Executive Conference Table / Grey	96"L x 48"D x 29.5"H	\$987.00		\$
10' ABERDEEN Executive Conference Table / Grey	120"L x 48"D x 29.5"H	\$1128.00		\$
Accessories				
Glow Cube	20"L x 20"D x 20"H	\$338.00		\$
6 Pocket Literature Stand - Silver	10.75"L x 14.25"D x 58"H	\$270.00		\$
6 Pocket Literature Stand - Black	10.75"L x 14.25"D x 58"H	\$270.00		\$
Refrigerator / Black 3.3 CuFt (60Hz)	19"L x 17.6"D x 33.2"H	\$390.00		\$
Lighted Marquee Lettering / White	3' H w/ Clear LED Bulbs	\$300.00		\$
8' Foliage Backdrop Wall	8'L x 24"D x 8'H	\$1480.00		\$
16' Foliage Backdrop Wall	16'L x 24"D x 8'H	\$2437.00		\$
33"H Boxwood Hedge Wall	48"L x 14"D x 33"H	\$675.00		\$
79"H Boxwood Hedge Wall	38"L x 14"D x 79"H	\$795.00		\$
Stanchion Pole - Chrome	12"L x 37"H	\$95.00		\$
Stanchion Velvet Rope / Red, Black, or Orange	5'	\$60.00		\$
Retractable Belt Stanchion / Black	14"L x 40"H	\$112.00		\$
Bag Rack	45"H 16" Square Arm	\$82.00		\$
Coat Rack	12.6"D x 67"H	\$225.00		\$
Free Standing Mirror	24"W x 24.5"D x 64"H	\$293.00		\$
TURINO Floor Lamp	10"W x 10"D x 67"H	\$195.00		\$
Throw Pillows (Various Colors)	18"L x 18"W	\$30.00		\$
VENETIAN Back Bar / White	37"L x 7.8"D x 59"H	\$567.00		\$

Credit Card Information				
Credit Card #:			Total Product \$	
Exp. Date:	Security Code	Zip Code	Misc. \$	
<div style="display: flex; justify-content: space-around;"> Mastercard Visa AMEX Discover </div>			Late Fee % \$	
Cardholders Name:			Sub Total \$	
(Please Print)			Sales Tax \$	
Cardholders Signature:			TOTAL DUE \$	

NAME OF CONFERENCE	START DATE	END DATE

LEVEL OF SERVICE	TYPICAL USAGE
5 AMP	<ul style="list-style-type: none"> • Charge phones or laptops • Small monitors (up to 32")
10 AMP	<ul style="list-style-type: none"> • Larger monitors (32" and above) • Up to three LED overhead lights or a large LED light strip
20 AMP	<ul style="list-style-type: none"> • Two or more large monitors • Three or more LED lights • Small appliances like a K-Cup coffee maker

IF YOU NEED HELP LOCATING YOUR SHOW, PLEASE FOLLOW THE STEPS BELOW:

1. ENTER SHOW DATE(S) YOU WERE PROVIDED WITH
2. SELECT "FLORIDA" IN THE "STATE" DROPDOWN
3. SELECT "ORLANDO" IN THE "CITY" DROPDOWN
4. SELECT "ROSEN SHINGLE CREEK" IN THE "VENUE" DROPDOWN
5. HIT SEARCH
6. SELECT YOUR SHOW FROM THE SEARCH LIST

<https://eventnow.encoreglobal.com/>

CLICK HERE TO ORDER UP TO TWO ELECTRICAL DROPS

CLICK HERE TO CONFIGURE YOUR MONITOR OPTIONS

SPECIALTY SERVICES

ANYTHING ABOVE 20AMPS

208V ELECTRICAL SERVICES

WATER LINES

AIR LINES

VIDEO EQUIPMENT

23-24" HD MONITOR (TABLETOP ONLY)

32" MONITOR (TABLETOP OPTIONAL)

48" MONITOR

55" MONITOR & FLOOR STAND PACKAGE

70" MONITOR & FLOOR STAND PACKAGE

PC BASED LAPTOP

WIRELESS REMOTE PRESENTER

LED UPLIGHTING

IF SPECIALTY SERVICES ARE REQUIRED, EMAIL rsce Exhibits@encoreglobal.com TO SUBMIT A REQUEST FOR A QUOTE

RIGGING REQUESTS

If rigging is required, please use the following link to request approval.

<https://www.encoreglobal.com/rigging-portal/>

If you are experiencing technical difficulties on-site, please contact Encore at 407-616-4556 or 407-616-3511

PRE-ORDER TECHNOLOGY FORM

ALL ORDERS MUST BE RECEIVED APRIL 15TH, 2025 IN ORDER TO RECEIVE PRE-ORDER PRICING.

RENTAL EQUIPMENT AND INTERNET PRICING ARE LENGTH OF SHOW. (Up to 5 Days)

Event Name: 50th Annual Regional Anesthesiology and Pain
 Booth Name and #: _____

Install Date and Time: _____
 Removal Date and Time: _____
 On-Site Test and Time: _____

On-Site Contact: _____
 On-Site Contact Cell #: _____
 On-Site Contact Email: _____

Wireless Internet Prices are per booth, length of event. Connections capped at a maximum speed of 5Mbps.	Pre-Order Rate	Rack Rate	Total
1-5 Wireless Connections	\$600	\$720	
6-10 Wireless Connections	\$1,020	\$1,200	
11-15 Wireless Connections	\$1,305	\$1,490	
16-20 Wireless Connections	\$1,500	\$1,890	
21-25 Wireless Connections	\$1,650	\$1,980	
26-30 Wireless Connections	\$1,800	\$2,160	
For more than 30 wireless users in a booth, please call for pricing.			

Wired Internet/ Dedicated Bandwidth Prices are per location, length of event, with private IP addresses. If cabling under carpet, please call to schedule location and provide diagram.	Pre-Order Rate	Rack Rate	Total
5Mbps Dedicated Connection	\$3,000	\$3,600	
10Mbps Dedicated Connection	\$4,500	\$5,400	
15Mbps Dedicated Connection	\$6,000	\$7,200	
20Mbps Dedicated Connection	\$7,500	\$9,000	
Additional Connections within the same location (requires network switch) Specify QTY:	\$100	\$150	
Network Switch (Up to 8 Ports)	\$250	\$300	

HD Monitors Includes a table stand and 5ft cable.	Price	Qty.	Total
42" Monitor (Includes Dual Pole Stand)	\$800		
55" Monitor (Includes Dual Pole Stand)	\$1,000		
65" Monitor (Includes Dual Pole Stand)	\$1,500		
75" Monitor (Includes Dual Pole Stand)	\$1,800		
90" Monitor (Includes Dual Pole Stand)	\$2,500		
Additional sizes available upon request			

Laptops/ Tables	Price	Qty.	Total
Laptop	\$225		
Apple MacBook Pro	\$315		
Tablet	\$185		

Internet SUBTOTAL	\$
26% Service Fee	\$
6.5% Tax on Service Fee Only	\$
INTERNET GRAND TOTAL	\$

Rental Equipment SUBTOTAL	\$
26% Service Fee	\$
SUBTOTAL	\$
6.5% Sales Tax (On Rental Equipment & Service Fee)	\$
RENTAL EQUIPMENT GRAND TOTAL	\$

Telecommunication SUBTOTAL	\$
26% Service Fee	\$
12.72% Communication Tax (TELECOMMUNICATION)	\$
6.5 % Sales Tax (SERVICE FEE ONLY)	\$
TELECOMMUNICATION GRAND TOTAL	\$

Telecommunication Services Additional Phone options and international calling available. Please call for assistance.				
Cisco Digital Phones Installation fee of \$150 included in first day pricing.	Qty.	Single Day Rate	Add'l Days	Total
House Phone		\$180	\$30	
DID or Polycom Local/ 800		\$250	\$100	
DID or Polycom Local/ 800/ Long Distance		\$300	\$150	
ATA (Analog Phone Adapter)		\$250	\$100	

Network Configuration	Pre-Order Rate	Rack Rate	Qty.	Total
Static IP (One Time Fee)	\$150/each			
Network Extension / Drop	\$250	\$300		
Private VLAN	\$1,200	\$1,450		
Public VLAN	\$1,800	\$2,160		
Custom SSID	\$1,200	\$1,500		

Technology Accessories	Price	Qty.	Total
5ghz Wireless Dongle	\$50		
USB to Ethernet Dongle	\$50		
HDMI Cable (25ft)	\$50		
VGA Cable (25ft)	\$50		

Ask us about our sponsorship opportunities!

Please Note the Following:

- * Additional \$250 fee for all orders placed on site, service charge and applicable taxes will be applied.
- * Internet and Rental Equipment prices are for the length of the show (Up to five days).
- * For any items that are damaged or not returned, fees will be applied.
- * This includes, but is not limited to remotes, accessories, and etc.
- * The order form will not be altered in any way.
- * Millennium does not supply power. For power needs, please contact the exhibition company.
- * Orders cancelled with less than 72 hours' notice will incur a 50% cancellation fee. Orders cancelled on site will incur a 100% cancellation fee.
- * Dedicated bandwidth recommended for VOIP, video streaming or video conferencing.
- * Any unauthorized equipment will be disconnected.
- * Support will only be provided to MTG equipment.

Booth Diagram

Mark "X" where connections should be located

Front

Booth # _____

Booth # _____



Please note that your order is not complete until payment has been received.

Billing Information
Please Type or Print Clearly and Provide Business Card

Name of Event	Booth #		
Card Holder's Name	Phone #		
Company Name			
Billing Address of Credit Card	City	State	Zip Code
Email Address			

Once the form is completed and submitted, a Millennium Technology Sales Managers will input your information. Invoice(s) will be sent to the email address listed above for your credit card payment to be submitted.

- * Due to PCI compliance, we can no longer accept any CC authorization forms. **Please do not include your CC numbers on this form.**
- * Please provide all information requested. Incomplete forms will delay processing.
- * Make sure to write the billing address of the credit card that will be used for payment.
- * Full payment is required prior to services being rendered.
- * Millennium Technology Group (MTG) accepts Visa, MasterCard, American Express, and Discover.

I agree in placing this order and I have accepted Millennium Technology Group's Rental Agreement Terms and Conditions, including Millennium Technology Group's payment policy.

Cardholder's Signature

Date

Email order to Millennium Technology Group Attn: Convention Technology Sales Address: 4000 Destination Pkwy, Orlando, FL 32819

Phone: (407) 996-5865 24/7 Support: (407) 996-3333 Email: ConventionSales@MTG-FL.com

TECHNOLOGY TERMS AND CONDITIONS LIMITATION OF LIABILITY

EXCEPT FOR CLAIMS FOR PHYSICAL INJURY TO PERSONS, MILLENNIUM TECHNOLOGY GROUP (MTG) AND ITS SUPPLIERS OR SUBCONTRACTORS WILL NOT BE LIABLE FOR ANY SPECIAL, OR CONSEQUENTIAL DAMAGES OR FOR LOSS, DAMAGE OR EXPENSE DIRECTLY OR INDIRECTLY ARISING FROM CUSTOMER'S USE OR INABILITY TO USE THE SYSTEM EITHER SEPARATELY OR IN COMBINATION WITH OTHER EQUIPMENT OR SOFTWARE OR FOR COMMERCIAL LOSS OF ANY KIND (INCLUDING LOSS OF BUSINESS PROFITS) BASED UPON BREACH OF WARRANTY, BREACH OF CONTRACT, NEGLIGENCE, STRICT TORT OR ANY OTHER LEGAL THEORY WHETHER OR NOT MTG OR ITS SUPPLIERS OR ITS SUBCONTRACTORS HAVE BEEN ADVISED OF THE POSSIBILITY OF SUCH DAMAGE OR LOSS. IN NO EVENT SHALL LIABILITY EXCEED A REFUND OF AMOUNTS ACTUALLY PAID TO MTG BY COMPANY FOR THEIR NETWORK ATTACHMENT. SERVICES ARE PROVIDED BY MTG ON AN 'AS IS' AND 'AS AVAILABLE' BASIS. MTG MAKES NO REPRESENTATIONS OR WARRANTIES OF ANY KIND, EXPRESS OR IMPLIED, AS TO THE OPERATION OF MTG SERVICE OR THE INFORMATION, CONTENT, MATERIALS, OR PRODUCTS INCLUDED IN MTG SERVICE. NO WARRANTIES ARE MADE OTHER THAN PROVIDING YOU WITH OUR EQUIPMENT IN GOOD WORKING ORDER. YOU ACKNOWLEDGE THAT BOTH THE EQUIPMENT AND THE MANUFACTURERS OF SAID EQUIPMENT ARE ACCEPTABLE TO YOU. YOU FURTHER ACKNOWLEDGE THAT WE HAVE NOT MADE AND DO NOT MAKE ANY WARRANTY EITHER EXPRESSED OR IMPLIED INCLUDING BUT NOT LIMITED TO: A) THE FITNESS OR DESIGN OF THE EQUIPMENT; B) THE MERCHANTABILITY OF THE EQUIPMENT OR ITS FITNESS FOR ANY PARTICULAR PURPOSE; C) ANY PATENT, COPYRIGHTS OR TRADE SECRET INFRINGEMENTS AND D) THE COMPLIANCE OF THE EQUIPMENT WITH ANY REQUIREMENTS OF LAW, RULES, SPECIFICATIONS OR CONTRACT.

- CONDITION FOR PROCESSING SERVICE CONTRACT/ON-TIME INSTALLATION:** (a) Payment for service must accompany contract. (b) Incomplete contract forms will delay processing, please provide all information requested. (c) Booth number(s) must be identified on face of form. (d) Complete Floor Plan itemizing location of connections in booth must be designated on form or customer provided diagram(s) 3 days before move-in date (g) Orders/changes received on day of show move-in will be worked after other orders are complete.
- TERM:** The rental shall commence on the day the equipment/services are delivered to you and shall continue until the equipment/services are returned, complete and in good working order.
- TITLE:** Only MTG personnel are authorized to modify system wiring or cabling. Material and equipment furnished by MTG for this service order shall remain the property of MTG. You acknowledge that the equipment/services rented by you belongs to us and that you cannot sell, pledge, mortgage or otherwise dispose of the equipment.
- LOCATION:** The equipment shall be kept at the location you have provided us and may not be moved or relocated without our prior written permission. In the event of loss, you agree to promptly reimburse us for the replacement cost of such equipment and claims for all losses and injuries caused by such equipment.
- MODIFICATION AND ADDITIONAL WORK:** If, at the request of or with prior consent from the Customer, MTG has performed work or rendered other performances which goes beyond the substance or scope of the agreed services, the Customer shall pay for that work or performance according to our usual rates. Expanding or modifying a system analysis, a design or specifications shall also constitute additional work.
- REPAIRS:** During the term of rental, we are responsible for the maintenance of our equipment resulting from every day wear and tear. If the equipment malfunctions, you must notify us immediately and we will, at our discretion, repair or replace the defective equipment in a timely manner. If the equipment is damaged in any manner you will be responsible for all costs, including but not limited to service fees, repair fees, or full replacement costs.
- CREDIT APPROVAL:** We are not obliged to deliver the equipment unless and until your credit is approved by us.
- LATE CHARGES:** If any payments have not been made by the conclusion of the event, we may impose a late charge of 1.5% per month.
- PAYMENT:** Payment & Order forms must be received no later than 14 days prior to the first day of the event to avoid Pre-Order Penalty Fee of \$100. If ordering on site or after event move-in has started there is a \$150 On Site Order Fee that will be applied. Pricing listed on this contract does not include Federal, State, Local or other Taxes. Taxes/Tax surcharges will be included in your final bill. Checks must be received a minimum of ten days prior to the first day of service. **The Customer shall pay invoices in accordance with the payment conditions stated on the invoice. The Customer shall not be entitled to set off or to suspend a payment.**
- INTERNET SECURITY DISCLAIMER:** MTG does not provide security, such as but not limited to firewalls etc. for any data connection(s) we provide. It is the sole responsibility of the exhibitor or customer to provide any necessary security. With execution of this document the Customer is agreeing to the Terms and Conditions of this document and will hold MTG; its agents and contracts harmless for any and all liabilities arising from the use of non-secured data circuits.
- SHARED INTERNET SERVICES SPECIFIC:** Proxy Servers are not allowed with any of MTG's shared Internet/Network Services. This includes, but is not limited to, Premium Internet & Basic Internet. MTG can engineer a custom dedicated network(s) to accommodate such special requests.
- ORDER FORM:** Rates listed include a single IP address with standard installation to the booth in the most convenient manner. To connect additional devices to the bandwidth product a MTG assigned IP address or additional device charge must be purchased.
- INTERNET PERFORMANCE DISCLAIMER:** MTG does not guarantee the performance, routing, or throughput, either expressed or implied, of any data connectivity with regards to the Internet and/or Internet backbones beyond any facility we service.
- GENERAL PROVISIONS:** a) The laws of the State of Florida shall govern this Agreement between you and MTG. b) Although you do not have the right to assign this Agreement, we do. If we exercise this right, we may direct you to make all future payments to another party at their address. c) You hereby waive trial by jury in any action or proceeding pertaining to this Rental Agreement. d) Paragraph headings are for convenience only.
- PUBLICITY:** Notwithstanding anything to the contrary in the Agreement or applicable Statements of Work, MTG shall be permitted to disclose in summary form the nature of work performed for clients under the applicable Statement of Work; however, MTG shall not disclose the proprietary business processes of Client or otherwise result in any breach of any other term of this Agreement.
- WIRELESS SPECIFIC:** The use of any wireless device that interferes with the facility wireless data frequency is prohibited.
- RENEWALS AND RATE CHANGES:** The rental will automatically be renewed for successive rental periods following the initial rental term.
- PERFORMANCE:** MTG shall, to the best of its ability, do its utmost to perform the services with due care and, where appropriate, in accordance with the agreements and procedures recorded in writing with the customer. All of MTG's services shall be performed on the basis of a best efforts obligation, unless and insofar as the MTG has expressly promised a result in the written Agreement and the result concerned has also been described with sufficient definiteness. Any agreements concerning a service level must always be expressly agreed in writing.

19. **USAGE:** You may use our equipment, but you may not abuse it. In particular, you must provide a suitable location, including appropriate electrical power, for our equipment and comply with the manufacturer's operating instructions. If any software is supplied with the property, you agree to be bound by all applicable licenses and copyright laws and, with regard to Microsoft products, you further acknowledge that use of the Microsoft software accompanying our equipment is governed by Microsoft's End User License Agreement attached hereto.

20. **VIRUS PROTECTION REQUIREMENT – WARNING** – MTG requires that all devices directly or indirectly accessing MTG's Network have the latest virus scan software, windows security updates, system patches, and any other technological precautions necessary to protect yourself and others from viruses, malicious programs and other disruptive applications. Any device, which adversely impacts MTG's Network, will be disconnected from the network with or without prior notice at MTG's discretion. The device(s) in question will remain disconnected from the network until all issues are adequately resolved. Additional charges may apply for trouble diagnosis and/or problem resolution.

21. **CUSTOMER EQUIPMENT:** Customers wishing to place their equipment within the IDF's must obtain authorization to do so through MTG. MTG nor Rosen Hotel & Resorts will be held responsible for the loss or damage of customer provided equipment. This includes but not limited to damage due to power, liquids, leaks, or other naturally occurring events. Plugging in to any outlet or circuit currently utilized by MTG equipment or Rackspace is strictly prohibited. Power must be ordered from the hotel's convention power provider. All access to IDF's require a representative from MTG to be present at all times. No keys will be issued to a customer or group and the door must remain securely locked at all times. All patching and un-patching of ports and or fiber can only be performed by a MTG representative.

22. **USE OF NETWORK CONNECTIONS:** a) The network attachment to be provided by MTG may be used only by the employees of the company, its agents and consultants while performing service for the company and will not be resold or distributed to other companies. The services being provided by MTG will facilitate communications between the Company's authorized users and the entities reachable through the national Internet. Users of MTG services shall use reasonable efforts to promote efficient use of the networks to minimize, and avoid if possible, unnecessary network traffic and interference with the work of other users of the interconnected networks. b) Users of MTG services shall not disrupt any of the MTG or other associated networks in part or as a whole. MTG services shall not be used to transmit any communication where the meaning of the message, or it's transmit distribution, would violate any applicable law or regulation or would likely be highly offensive to the recipient or recipients thereof. c) All devices for which MTG directly or indirectly provides Internet/Network connectivity must pay a connection charge or purchase a MTG assigned IP address. d) The choice of Internet Service Provider (ISP) is at the sole discretion of MTG e) MTG is the exclusive provider of all wired and wireless data services. f) Wired/Wireless Devices not authorized by MTG are strictly prohibited. Anyone wishing to showcase wireless products must contact MTG three weeks in advance of their show to investigate the potential of MTG engineering a customized cohesive network operating without interference g) Rates listed include a single IP address via DHCP, bringing the service to the booth in the most convenient manner and does not include computer equipment, NIC card, TCP/IP software or power to the booth.

23. **CANCELLATIONS & ADJUSTMENTS:** No adjustments to invoices will be made after the close of the Event. Claims will not be considered unless filed in writing by Exhibitor/Client prior to close of Show/Event. All orders cancelled within 72 hours of the first day to the Event whether it be by the Exhibitor, due to the cancellation of an Event or their non-participation, will be charged a cancellation fees equal to 50% - 100% of the total order, based on the status of move-in, work performed and/or MTG set-up costs or expenses. Orders cancelled on site will incur a 100% cancellation fee. Some broadband services and special circuits cannot be cancelled once ordered and will incur full charges listed /quoted. Credit will not be given for service installed and not used.

24. **INDEMNIFICATION:** a. You shall defend, indemnify and hold MTG harmless against all costs and expenses, including reasonable attorney's fees, associated with the defense or settlement of any claim that: i. MTG's use, access or modifications of any software that you have requested that we use, access or modify as part of the Services infringes any patent, copyright, trademark, trade secret or other intellectual property right, or ii. Your use of any Services in violation of any requirements or representations in this agreement violates any law or infringes any patent, copyright, trademark, trade secret or other intellectual property right. b. You further shall pay any judgments or settlements based on any such claims.

25. **ENTIRE AGREEMENT:** These terms and conditions together with any documents expressly referred to in them, contain the entire agreement between us relating to the subject matter covered and supersede any previous agreements, arrangements, undertakings or proposals, written or verbal: between us in relation to such matters. No verbal explanation or verbal information given by any party shall alter the interpretation of these terms and conditions. In agreeing to these terms and conditions, you have not relied on any representation other than those expressly stated in these Terms and Conditions and you agree that you shall have no remedy in respect of any misrepresentation, which has not been made expressly in these Terms and Conditions.

26. **PERSONAL DATA PROTECTION** a. "Personal Data" means any information regarding any identified or identifiable person associated with the meeting, that may be provided or discovered during the course of performing under the meeting Agreement. Hotel may process and use the Personal Data only to the extent necessary to perform its obligations under the meeting Agreement. Hotel may disclose the Personal Data only to Hotel's agents, employees and subcontractors as necessary to perform the Hotel's obligations under the meeting Agreement, who have received training on the handling of Personal Data from Hotel, and who are bound by confidentiality obligations. Hotel may disclose Personal Data as required to fulfill regulatory or legal requirements within the travel industry. Hotel may not sell, rent or lease Personal Data to any other party. Hotel may not use any Personal Data to send direct marketing materials to Client, its members or employees, unless they have provided their explicit written consent or have otherwise provided personal data for such purpose, i.e. have opted in to receive such materials from Hotel. b. Hotel will use the same reasonable degree of care to prevent the unauthorized use, dissemination or publication of the Personal Data, as it uses to protect its own information of similar nature, and will implement any technical and organizational measures to protect personal data which are required by the applicable law. Hotel will adhere to all applicable export, personal data protection and security laws, regulations and rules when collecting, using, storing, transferring and otherwise processing Personal Data. Hotel agrees to notify Client if it becomes aware of any actual, suspected or alleged unauthorized use of, disclosure of, or access to Personal Data by itself or others that also creates a notification obligation to affected individuals under state or federal law. In the event of such a security incident, Hotel will cooperate with Client in accordance with the applicable laws, including: conducting the investigation; cooperating with authorities; and notifying affected persons, credit bureaus, other persons or entities deemed appropriate by the Client.

LEAD RETRIEVAL ORDER FORM [Order Online](#) **DISCOUNT DEADLINE: April 4, 2025**

ExpoBadge Lead Retrieval Equipment <i>Equipment descriptions on Page 2</i>	DISCOUNT	REGULAR	QUANTITY	TOTAL
--	-----------------	----------------	-----------------	--------------

Handheld Scanners:

(Battery operated scanners; no electricity required)

ExpoBadge Axist	\$475	\$495		
ExpoBadge Axist with Printer	\$575	\$605		

Mobile Application:

ExpoBadge Lead Retrieval App <i>(one license)</i>	\$335	\$350		
Additional Licenses	\$190	\$205		

ExpoBadge Extras:

Delivery, Setup, and Training	\$95	\$100		
Personalized Action Codes	\$80	\$110		
USB Flash Drive	\$65	\$85		
Paper: Additional Roll	\$17	\$22		
Digital Literature Kiosk	\$275	\$300		
ExpoBadge Badge Kit	\$475	\$475		
ExpoBadge API Developers Kit	\$850	\$850		

Federal Tax ID # 20-8676699

Sub Total:

Processing Fee:

\$15.00

Grand Total:

Company Information

COMPANY	CONTACT	BOOTH #
ADDRESS 1	CITY	ZIP CODE
ADDRESS 2	STATE	COUNTRY
EMAIL	PHONE	ONSITE PHONE

ONLINE ORDERS:

[ASRA2025](#)

EMAIL ORDERS TO:

orders@expobadge.com

MAIL ORDERS TO:

ExpoBadge, Inc.
1075 N. Tustin St. #6250
Orange, CA 92863, USA

Payment Information *Billing Zip Code Required

AMERICAN EXPRESS	MASTERCARD	VISA	CHECK
CREDIT CARD #	EXPIRATION DATE		
NAME ON CARD	*BILLING ZIP CODE		

FOR ASSISTANCE

CALL:



toll free 800-490-9941
+1-714-630-2945

Terms and Conditions: I have read and agreed to the following terms and conditions.

All equipment ordered must be picked up at the service desk prior to the start of the show, unless you have ordered Delivery and Set-up. Failure to pick up equipment does not entitle you to a refund. All equipment must be returned to the service desk within 1 hour of show close to avoid additional \$100.00 charge. A non-refundable charge of \$2,500.00 will be applied for each piece of equipment not returned to ExpoBadge, Inc. at the close of show. There will be a \$100.00 charge for the loss or damage of ExpoBadge data card. All cancellations must be submitted in writing 2 weeks prior to the start of the show; there are no refunds or cancellations after this time. There is a \$75.00 fee for all cancellations prior to 2 weeks before show. There is no refund on paper or badge kits. ExpoBadge, Inc. will not be responsible for the type or amount of data provided by show management. Liability for damage of any cause whatsoever will be limited to the total price of goods and services provided by ExpoBadge, Inc.

Please feel free to review our Privacy Policy and commitment to GDPR compliance [here](#).

ELECTRONIC LEADS DELIVERY: An email containing a link to your leads will be sent to the email address on file within 24 hours of the close of the show. Your leads will be available in multiple formats: Excel, .CSV, and .TXT

HANDHELD SCANNERS	DETAILS	LEADS FORMAT
<p>ExpoBadge Axist</p> 	<p>The ExpoBadge Axist is a wireless, handheld device (Android). Uploads lead detail in real-time. Includes an easy-to-use notes option for quickly recording notes specific to each lead. Leads can be accessed anytime from ExpoBadge's secure website.</p>	<p align="center">Electronic</p>
<p>ExpoBadge Axist with printer</p> 	<p>The ExpoBadge Axist with printer is a printer with a scanner connected <i>wirelessly</i>. This allows you the flexibility for multiple sales people to capture leads in your booth. With all the features of the ExpoBadge Axist, you will receive a paper and electronic copy of your leads.</p>	<p align="center">Paper and Electronic</p>

MOBILE APP	DETAILS	LEADS FORMAT
	<p>The ExpoBadge Lead Retrieval App is lead retrieval made smart. Scan, qualify, and survey attendees at events using your own personal smart phone or tablets (compatible with most Apple and Android devices). Works with or without an active internet connection or data plan; internet connectivity required for activation. Includes 1 license; additional licenses below.</p>	<p align="center">Electronic</p>

EXTRAS	DETAILS
<p>Delivery, Setup & Training</p>	<p>ExpoBadge staff will deliver your order to your booth, set-up the devices and train all exhibit booth personnel. [There is no charge for pick-up at ExpoBadge lead retrieval service desk.]</p>
<p>USB Flash Drive</p>	<p>Portable USB ver. 2.0 memory device. Leads will be downloaded to your Flash Drive upon return of equipment at the end of the show.</p>
<p>Digital Literature Kiosk</p>	<p>Use the Digital literature Kiosk to deliver digital documents to your booth visitors. Target your marketing and leverage your collateral investment by uploading your promotional material onto the Digital Literature Kiosk. You may post up to 10 unique pdfs.</p>
<p>ExpoBadge Badge Kit</p>	<p>The ExpoBadge Badge Kit is an encoding package intended for exhibitors that will be utilizing their own scanning equipment at the show. This kit will enable you to map the data scanned to the appropriate fields in your software. As soon as the badge has completed the approval process, the Badge Kit will be sent.</p>
<p>API Developers Kit</p>	<p>If you own your own Lead Retrieval system and would like to capture full attendee contact information in real time, our ExpoBadge API Developers Kit will allow you to retrieve each attendee's contact information via a direct API link to our registration database. We will send you API documentation, including instructions for your IT department to set up the data transfer and all credentials necessary to access our database. This will allow you to scan a badge on the tradeshow floor and send an ID to our database, which will immediately return the attendee's full contact information, making it available for direct import into your CRM or lead capture software. *This item also include our Badge Kit product.</p>

STANDARD ACTION CODES

ExpoBadge offers each exhibitor a complimentary list of standard qualifiers.

ADD TO MAILING LIST	HOT LEAD!	PRODUCT B	SCHEDULE DEMONSTRATION
CURRENT CUSTOMER	INQUIRY ONLY	PRODUCT C	SEND LITERATURE
DISTRIBUTOR	INTERESTED BUYER	PRODUCT D	SEND PRICING INFO
HAS PURCHASING AUTHORITY	OEM	PRODUCT E	VAR
HAVE SALES REP CALL	PRODUCT A	PRODUCT F	WANTS PRESENTATION

PERSONALIZED ACTION CODES

For an additional fee, you can personalize your action codes in order to better qualify each lead. Enter personalized action codes using our online order form or complete the template below.

Your codes will be ready with your equipment at our service desk. Maximum 35 characters per code.
 Custom Action Codes cannot include these characters: apostrophe ('), slash (/), backslash (\), period (.), carat (^), or quote (").

1	_____	11	_____
2	_____	12	_____
3	_____	13	_____
4	_____	14	_____
5	_____	15	_____
6	_____	16	_____
7	_____	17	_____
8	_____	18	_____
9	_____	19	_____
10	_____	20	_____